

PHOTOGRAPHIC IMAGING



Fernando Pereira

Instituto Superior Técnico



Many, Many Pictures ...

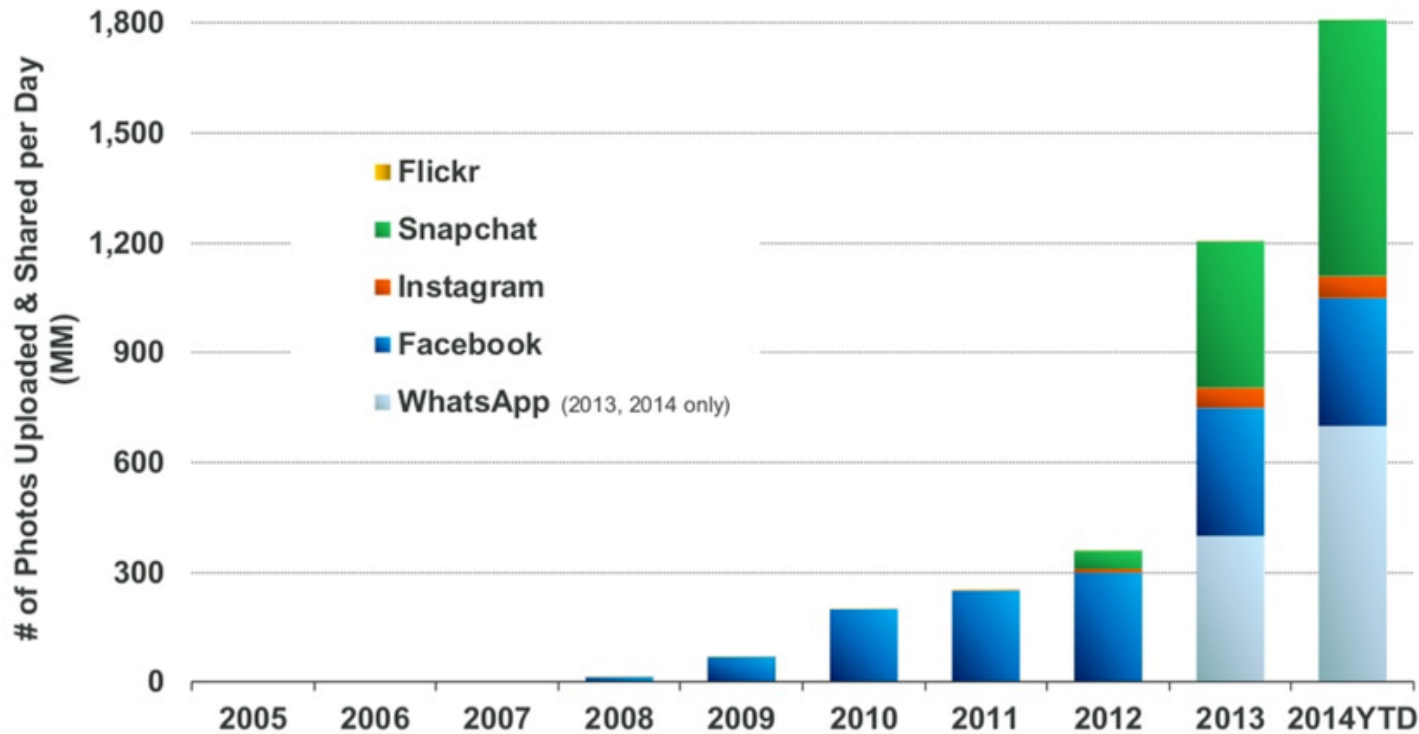

Source: KPCB 2014 Internet Trends, estimates based on publicly disclosed company data

Multilevel Photographic Image Coding (gray and colour)



OBJECTIVE

**Efficient representation of multilevel photographic images
(still pictures) for storage and transmission.**

Applications

★ Digital cameras



★ Image databases, e.g. museums, maps

★ Desktop publishing

★ Colour fax

★ Medical images

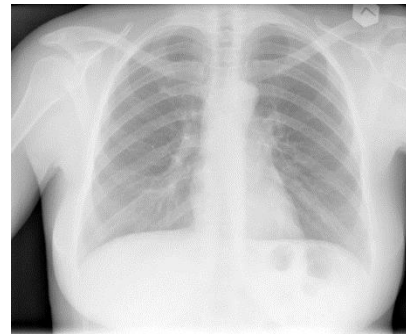

★ ...

★ and Digital cinema (!)



The Image Representation Problem ...

A image is created and consumed as a set of $M \times N$ luminance and chrominance samples with a certain number of bits per sample (P).

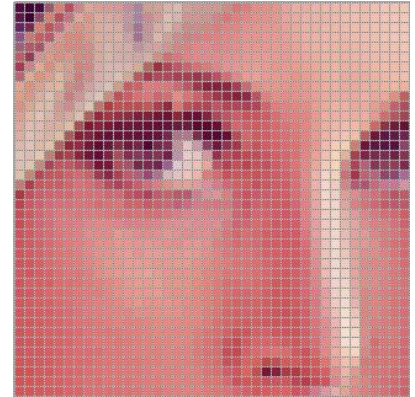

**Thus, the total number of bits ($M \times N \times P$)
- and so the memory and bandwidth –
necessary to PCM digitally represent an
image is HUGE !!!**



Source Coding: Original Data, Symbols and Bits

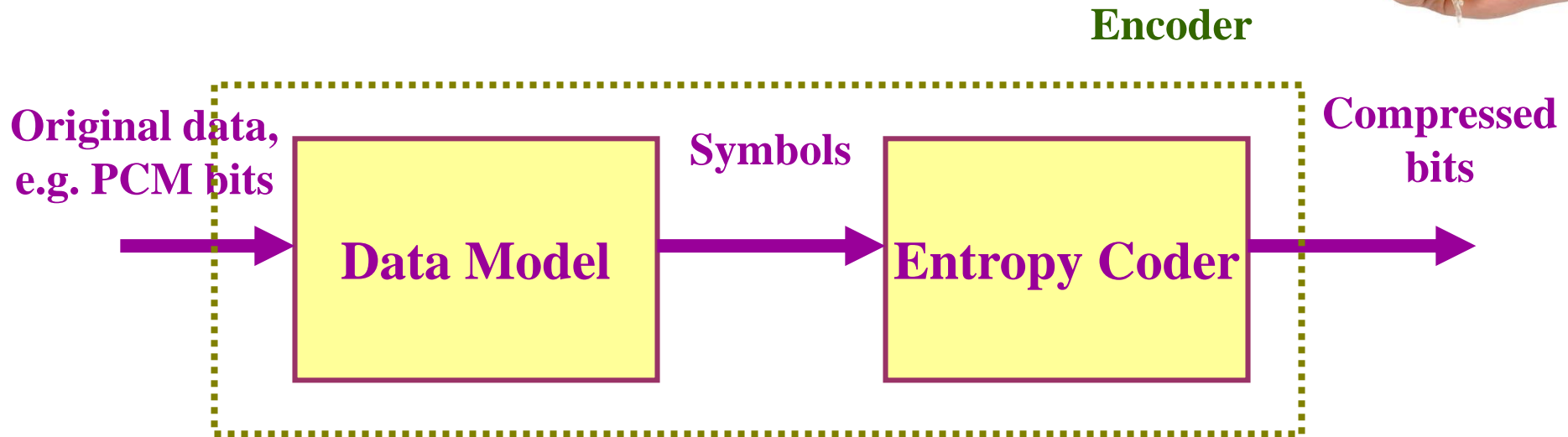

Source Coding implies two main steps:

- ★ **Data modeling** – Adopting a more powerful data representation model than the raw acquisition model, notably exploiting spatial and temporal redundancies as well as irrelevancy, targeting the relevant representation requirements
- ★ **Entropy coding** - Exploiting the statistical characteristics of the symbols produced by the data modeling process

Image (Source) Coding Objective

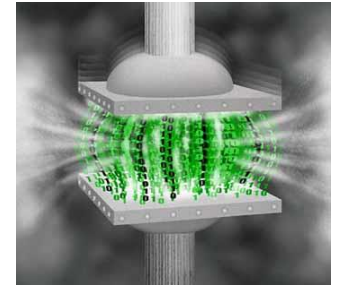

Image coding/compression deals with the efficient representation of images, satisfying the relevant requirements.

And these requirements keep changing, e.g., coding efficiency, error resilience, random access, interaction, editing, to address new applications and functionalities ...

Where does Compression come from ?

★ **REDUNDANCY** – Regards the similarities, correlation and predictability of samples and symbols corresponding to the image/audio/video data.

-> **redundancy reduction does not involve any information loss, implying it is a reversible process -> *lossless coding***

★ **IRRELEVANCY** – Regards the part of the information which is imperceptible for the visual or auditory human systems.

-> **irrelevancy reduction involves removing non-redundant information, implying it is an irreversible process -> *lossy coding***

Source coding exploits these two concepts: for this, it is necessary to know the source statistics and the human visual/auditory systems characteristics.

Image Coding: Multiple Solutions

★ **DCT-based transform coding, e.g. JPEG standard**

JPEG

★ **Fractal-based coding**

★ **Vector quantization coding**

★ **Wavelet-based coding, e.g. JPEG 2000 standard**

JPEG
2000

★ **Lapped biorthogonal-based transform coding, e.g. JPEG XR standard**

★ ...

The JPEG Standard

(Joint Photographic Experts Group, joint ISO & ITU-T)

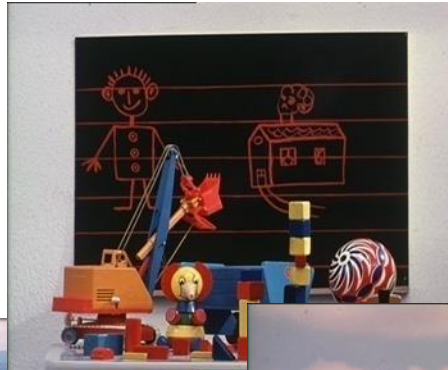

Definition of a generic compression standard for multilevel photographic images considering the requirements of most applications.

Interoperability, thus Standards !

★ Image coding is used in the context of many applications where interoperability is an essential requirement.



★ The interoperability requirement is satisfied through the specification of a **coding standard** which represents a voluntary agreement between multiple parties.

★ **To foster evolution and competition**, standards must offer interoperability through the specification of the minimum essential number of tools.

JPEG Standard Major Requirements

≈1985

- ★ **Efficiency** - The standard must be based on the most efficient compression techniques, notably for high quality.
- ★ **Compression/Quality Tunable** - The standard shall allow tuning the quality versus compression efficiency.
- ★ **Generic** - The standard must be applicable to any type of multilevel photographic images without restrictions in resolution, aspect ratio, color space, content, etc.
- ★ **Low Complexity** - The standard must be implementable with a reasonable complexity; notably, its software implementation on a large range of CPUs must be possible.
- ★ **Functional Flexibility** - The standard must provide various relevant operation modes, notably sequential, progressive, lossless and hierarchical.

JPEG Elements

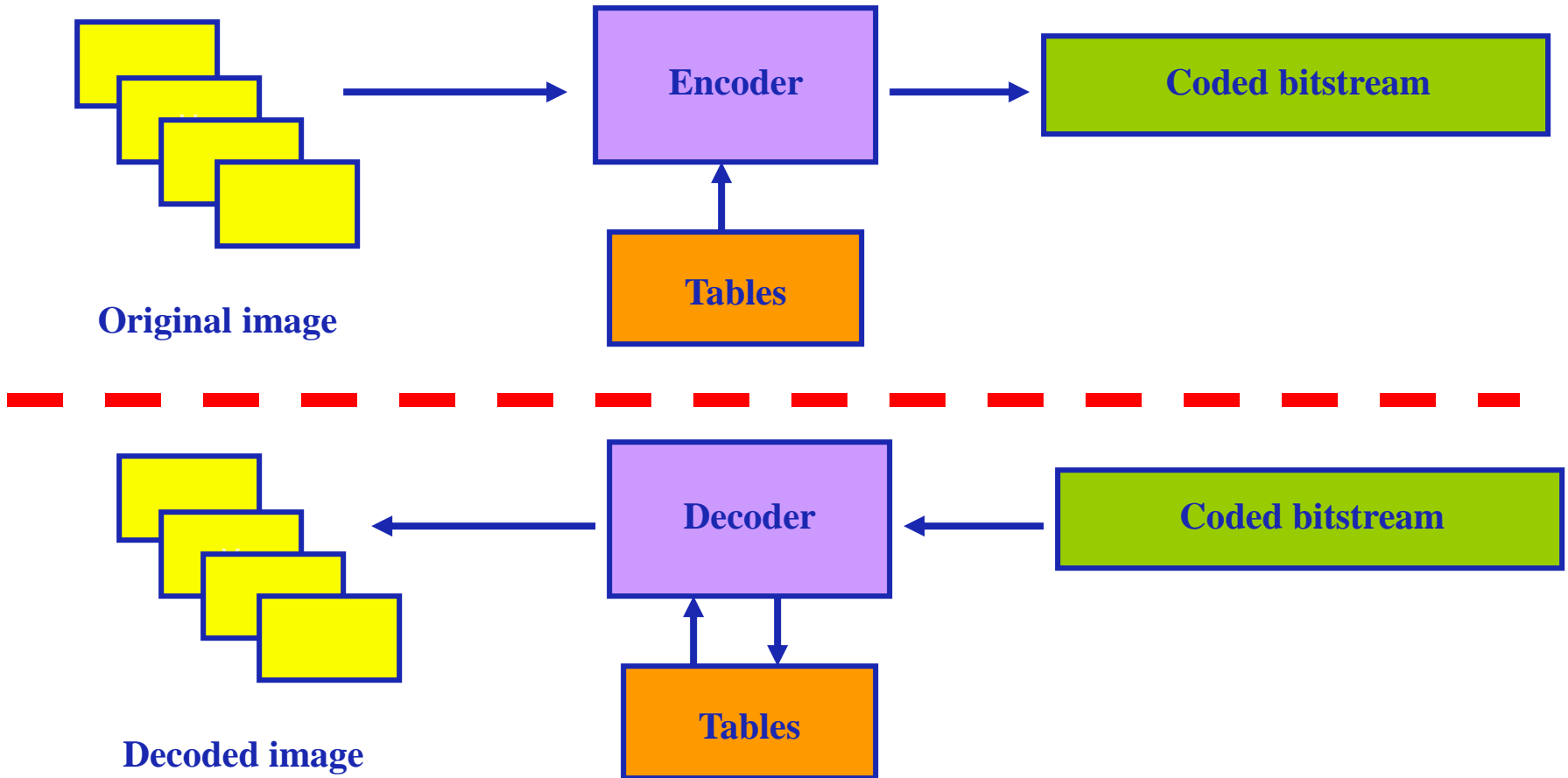

What Images can JPEG Encode ?

- ★ Size between 1×1 and 65535×65535
- ★ 1 to 255 colour components or spectral bands (typically $Y C_R C_B$ or RGB)
- ★ Each component, C_i , consists of a matrix with x_i columns and y_i lines
- ★ 8 or 12 bits per sample for DCT based compression
- ★ 2 to 16 bits per sample for lossless compression

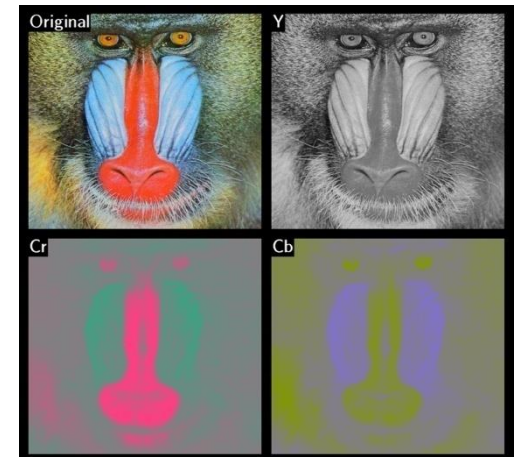
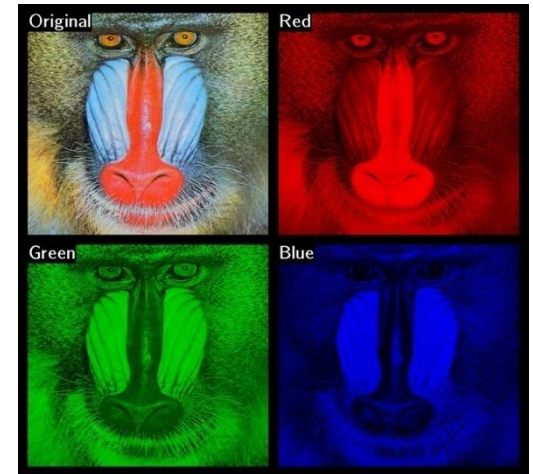

Types of JPEG Compression

- ★ **LOSSLESS** - The image is reconstructed with no losses, this means it is mathematically equal to the original; compression factors of about 2-3 may be achieved, depending on the image content.
- ★ **LOSSY** - The image is reconstructed with losses but, if desired, with a very high fidelity to the original (transparent coding); this type of coding allows achieving higher compression factors, e.g. 10, 20 or more; in the JPEG standard, this type of coding is based on the Discrete Cosine Transform (DCT).

JPEG Baseline Process

The most used JPEG coding solution is DCT based (lossy), called

BASELINE SEQUENTIAL PROCESS

and it is appropriate to inumerous applications. This process is mandatory for all systems claiming JPEG compliance.

DCT Based Coding

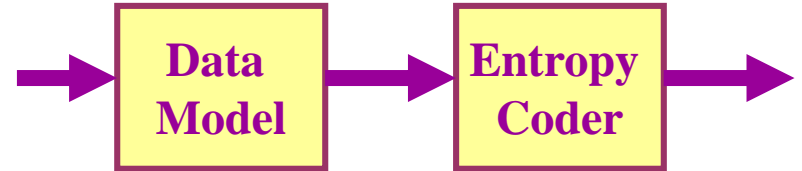

The joint action of the various JPEG Baseline encoder modules targets the reduction of the redundancy and irrelevancy contained in the images.

The first encoder part (data modeling) targets the generation of a signal without memory (elimination of spatial redundancy) and without irrelevancy.

The final entropy coding module targets the generation of equiprobable symbols in order to minimize the data to transmit (elimination of statistical redundancy).

DCT Based Image Coding

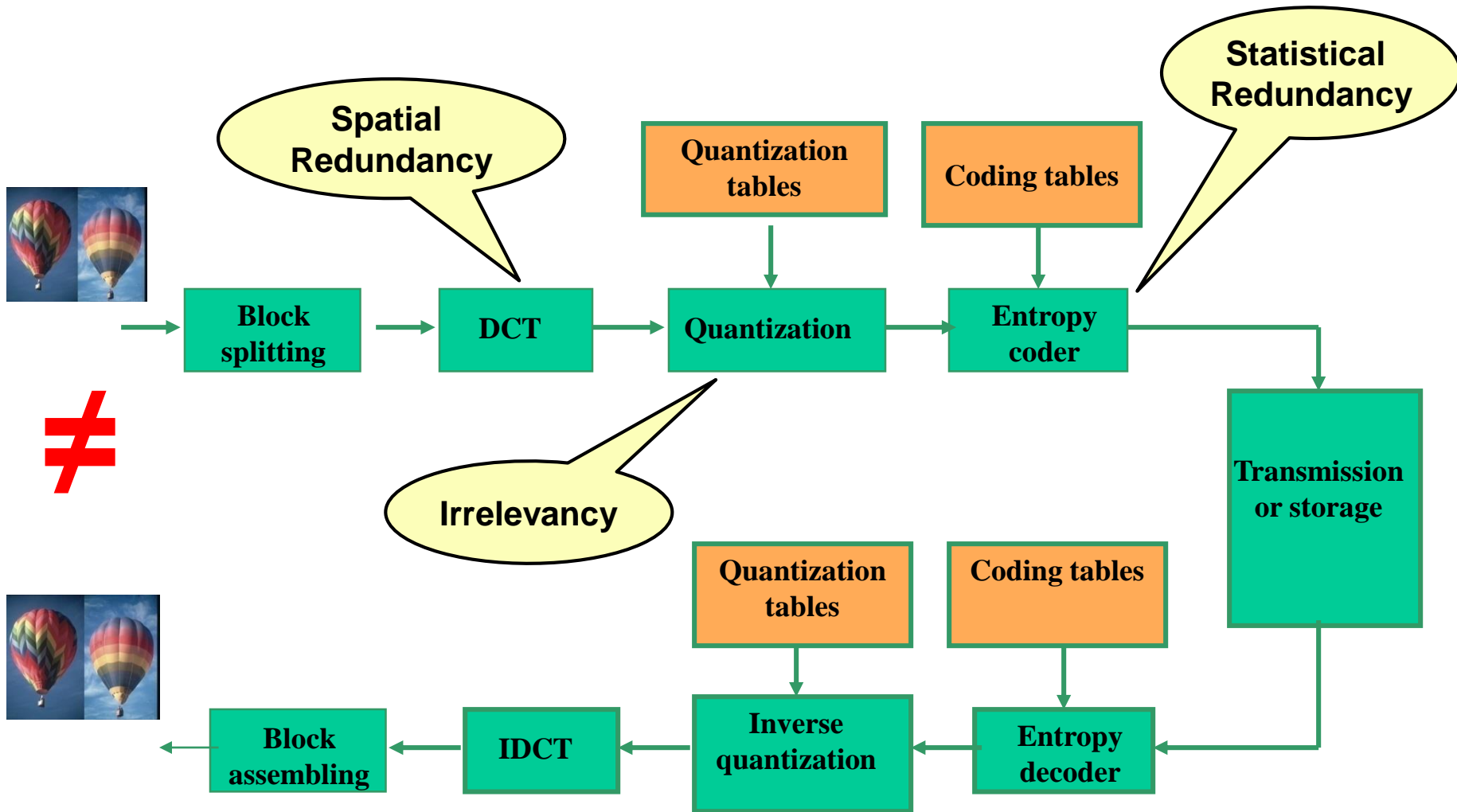

Why do we Transform Blocks ?

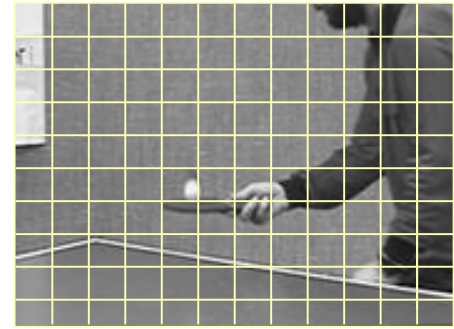

Basically, the transform represents the original signal in another domain where there is less spatial redundancy.

- ★ **The full exploitation of the spatial redundancy in the image would require applying the transform to blocks as big as possible, ideally to the full image.**
- ★ **However, the computational effort associated to the transform grows quickly with the size of the block used ... and the added spatial redundancy decreases ... So some trade-off is needed ...**

Applying the transform to blocks, typically of 8×8 samples, was a good trade-off between the exploitation of the spatial redundancy and the associated computational effort.

What is Transformed ?

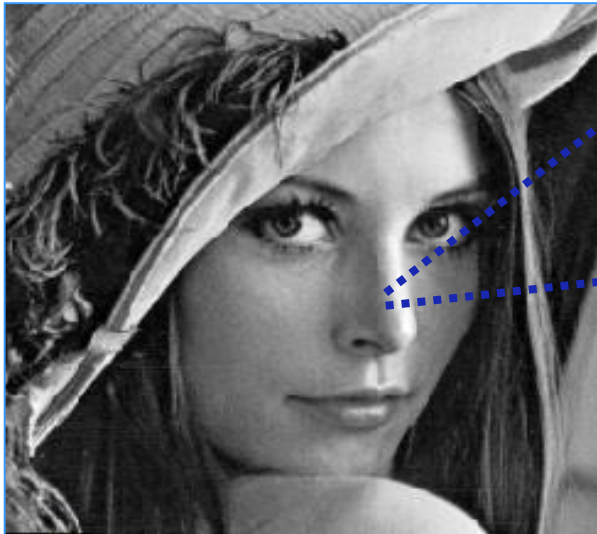

Tranform is applied block after block in the image ...

Same process (in parallel) for luminance and the chrominances !

Y =

87	89	101	106	118	130	142	155
85	91	101	105	116	129	135	149
86	92	96	105	112	128	131	144
92	88	102	101	116	129	135	147
88	94	94	98	113	122	130	139
88	95	98	97	113	119	133	141
92	99	98	106	107	118	135	145
89	95	98	107	104	112	130	144

JPEG Block Coding Sequence

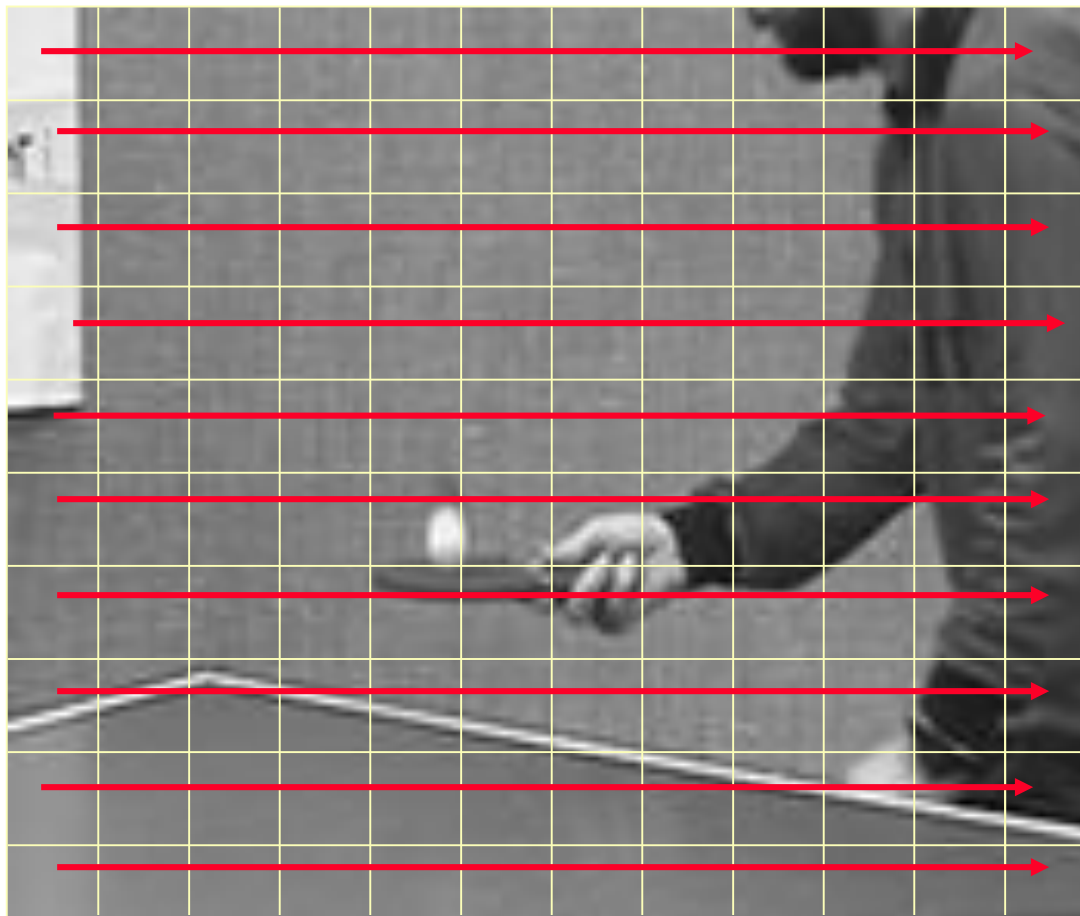

The Block Effect ...



Transform coding involves the division of the image into blocks of $N \times N$ samples to which the transform is applied, producing blocks with $N \times N$ transform coefficients.

A transform is formally defined by its direct and inverse transform equations:

$$F(u,v) = \sum_{i=0}^{N-1} \sum_{j=0}^{N-1} f(i,j) A(i,j,u,v)$$

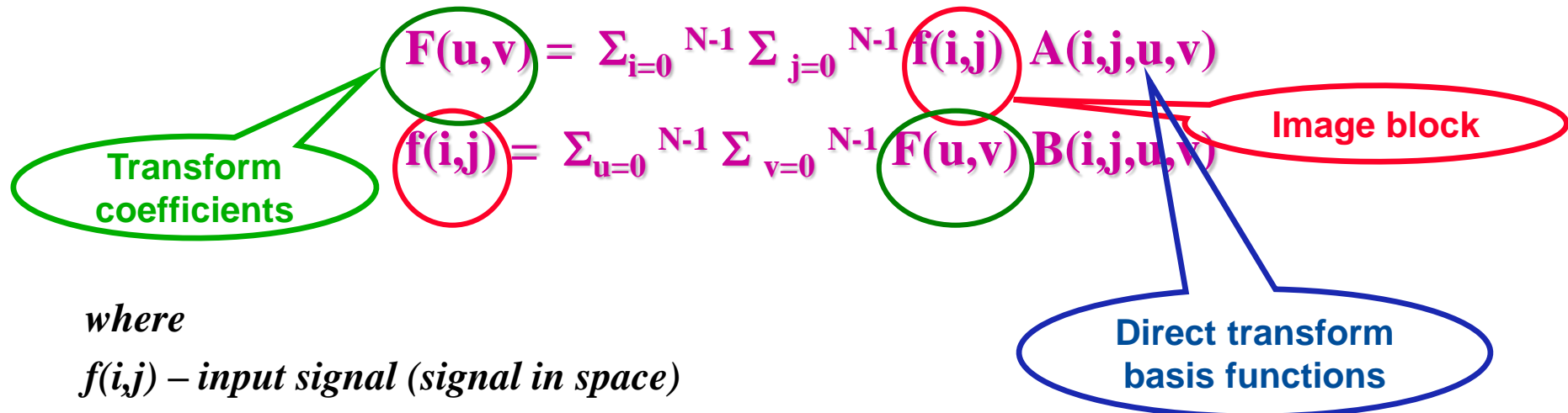
$$f(i,j) = \sum_{u=0}^{N-1} \sum_{v=0}^{N-1} F(u,v) B(i,j,u,v)$$

where

$f(i,j)$ – input signal (signal in space)

$A(i,j,u,v)$ – direct transform basis functions

$F(u,v)$ – transform coefficients (signal in frequency)

$B(i,j,u,v)$ – inverse transform basis functions

Relevant Transform Characteristics

Unitary transforms are used since they have the following relevant characteristics:

- ★ **Reversibility**
- ★ **Orthogonality of the transform basis functions**
- ★ **Energy conservation which means the energy in the transform domain is the same as in the spatial domain**

*Note 1: For unitary transforms, $A^*A=AA^*=I$ where I is the identity matrix and $*$ represents the transpose conjugate operation.*

Note 2: The transpose matrix results by permuting the lines and columns and vice-versa which means that the transpose is a $m \times n$ matrix if the original is a $n \times m$ matrix.

Note 3: The conjugate matrix is obtained by substituting each element by its conjugate complex (imaginary part with changed sign).

What Shall the Transform Provide in Image Compression ?

- ★ **REVERSIBILITY** – The transform must be reversible since the image to transform has to be recovered again in the spatial domain.
- ★ **INCORRELATION** – The ideal transform shall provide coefficients which are uncorrelated this means each one carries additional/novel information.
- ★ **ENERGY COMPACTATION** – The major part of the signal energy shall be compacted in a small number of coefficients.
- ★ **IMAGE INDEPENDENT TRANSFORM BASIS FUNCTIONS** – Since images show significant statistical variations, the optimal transform should be image dependent; however, the use of image dependent transforms would require its computation as well as its storage and transmission; thus, an image independent transform is desirable even if at some cost in coding efficiency.
- ★ **LOW COMPLEXITY IMPLEMENTATIONS** – Due to the high number of operations involved, the transform shall allow low complexity/fast implementations.

DCT Based Image Coding

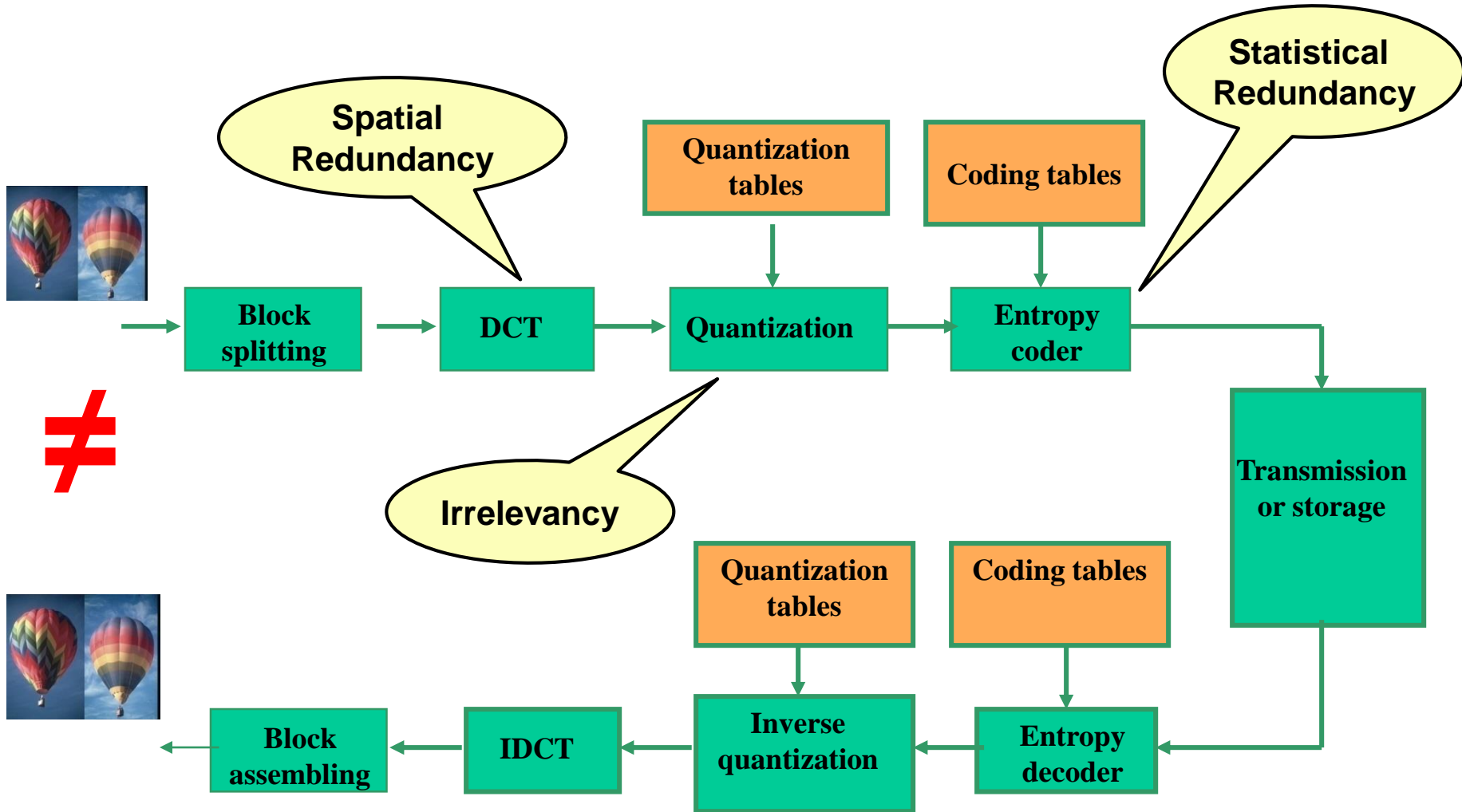

Luminance
Samples, $Y =$

87	89	101	106	118	130	142	155
85	91	101	105	116	129	135	149
86	92	96	105	112	128	131	144
92	88	102	101	116	129	135	147
88	94	94	98	113	122	130	139
88	95	98	97	113	119	133	141
92	99	98	106	107	118	135	145
89	95	98	107	104	112	130	144

**But what type
of transform is
good ?**

↓
Transform
↓

Transform
Coefficients =

898.0000	-149.5418	26.6464	-14.0897	0.7500	-5.7540	3.5750	0.0330
12.1982	-16.5235	-7.6122	5.2187	-0.2867	-1.9909	8.4265	1.2591
5.3355	-2.6557	2.3410	-9.9277	2.4614	4.4558	-3.1945	-3.1640
1.9463	-2.7271	1.5106	2.8421	-2.1336	-2.7203	-2.7510	5.4051
0.7500	-2.0745	0.8610	0.2085	2.5000	1.8446	2.0787	2.4750
7.9536	-2.6624	2.6308	0.4010	0.4772	3.3000	1.7394	0.3942
-4.1042	-0.1650	-0.6945	0.0601	0.0628	-0.7874	-0.8410	0.3496
-3.4688	2.3804	0.1559	0.8696	0.1142	-0.5240	-3.9974	-5.6187

Karhunen-Loève Transform (KLT)

The Karhunen-Loève Transform is typically considered the ideal transform because it achieves the

MAXIMUM ENERGY COMPACTATION

this means, if a certain limited number of coefficients is coded, the KLT coefficients are always those containing the highest percentage of the total signal energy.

The KLT base functions are based on the *eigen vectors of the covariance matrix for the image blocks ... and thus depend on each image block being transformed !*

Why is KLT Never Used ?

In practice, the use of KLT for image compression is negligible because:

- ★ **KLT basis functions are image dependent requiring the computation of the image covariance matrix as well as its storage and/or transmission.**
- ★ **Fast algorithms for its computation are not as good as for other transforms.**
- ★ **There are other transforms without the drawbacks above but still with a energy compactation performance only slightly lower than KLT.**





The DCT is one of the several sinusoidal transforms available; its basis functions correspond to discretized sinusoidal functions.

Transform coefficients

Image block

$$F(u, v) = \frac{2}{N} C(u) C(v) \sum_{j=0}^{N-1} \sum_{k=0}^{N-1} f(j, k) \cos\left(\pi \frac{u(2j+1)}{2N}\right) \cos\left(\pi \frac{v(2k+1)}{2N}\right)$$

$$f(j, k) = \frac{2}{N} \sum_{u=0}^{N-1} \sum_{v=0}^{N-1} C(u) C(v) F(u, v) \cos\left(\frac{u(2j+1)}{2N} \pi\right) \cos\left(\frac{v(2k+1)}{2N} \pi\right)$$

Image block

Transform coefficients

The DCT is the most used transform for image and video compression since its performance is close to the KLT performance for highly correlated signals; moreover, there are fast implementation algorithms available.

DCT Bidimensional Basis Functions (N=8)

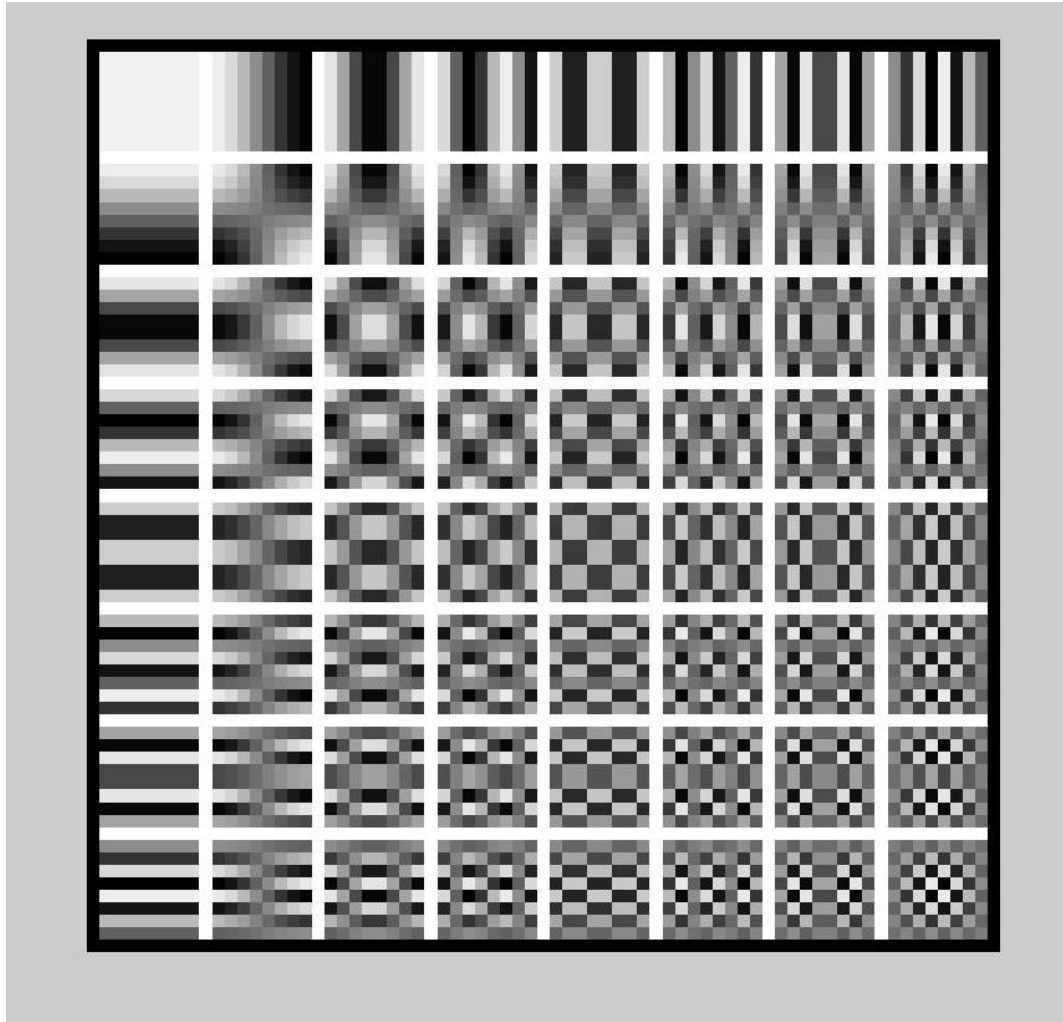

All existing and future images can be rather efficiently represented with these 64 (8x8) basic images !!!



Luminance
Samples, Y =

87	89	101	106	118	130	142	155
85	91	101	105	116	129	135	149
86	92	96	105	112	128	131	144
92	88	102	101	116	129	135	147
88	94	94	98	113	122	130	139
88	95	98	97	113	119	133	141
92	99	98	106	107	118	135	145
89	95	98	107	104	112	130	144

**64 PCM samples
are transformed
into 64 DCT
coefficients !**

**But more
compression
friendly !
With less spatial
redundancy !**

DCT

DCT
Coefficients =

898.0000	-149.5418	26.6464	-14.0897	0.7500	-5.7540	3.5750	0.0330
12.1982	-16.5235	-7.6122	5.2187	-0.2867	-1.9909	8.4265	1.2591
5.3355	-2.6557	2.3410	-9.9277	2.4614	4.4558	-3.1945	-3.1640
1.9463	-2.7271	1.5106	2.8421	-2.1336	-2.7203	-2.7510	5.4051
0.7500	-2.0745	0.8610	0.2085	2.5000	1.8446	2.0787	2.4750
7.9536	-2.6624	2.6308	0.4010	0.4772	3.3000	1.7394	0.3942
-4.1042	-0.1650	-0.6945	0.0601	0.0628	-0.7874	-0.8410	0.3496
-3.4688	2.3804	0.1559	0.8696	0.1142	-0.5240	-3.9974	-5.6187

How to Interpret a Transform ?



The formula for the inverse transform

$$f(i,j) = \sum_{u=0}^{N-1} \sum_{v=0}^{N-1} F(u,v) \cdot B(i,j,u,v)$$

Image
block

Weights

Basic image
blocks

expresses that the transform process may be interpreted as a decomposition of each image block in terms of certain basic functions – *the transform basis functions* – adequately weighted by the transform coefficients.

The Spectral Interpretation – As most transforms use basis functions with different frequencies (in a broad sense), the decomposition in basis functions assumes a spectral meaning where each coefficient represents the fraction of energy in the image corresponding to a certain basis function/frequency.

How to Interpret a Transform ?



The formula for the inverse transform

$$f(i,j) = \sum_{u=0}^{N-1} \sum_{v=0}^{N-1} F(u,v) \cdot B(i,j,u,v)$$

Image
block

Weights

Basic image
blocks

expresses that the inverse transform process may be interpreted as a reconstruction/synthesis of each image block by adding the relevant set of basic functions – *the transform basis functions* – adequately weighted by the transform coefficients.

The Spectral Interpretation – As most transforms use basis functions with different frequencies (in a broad sense), the decomposition in basis functions assumes a spectral meaning where each coefficient represents the fraction of energy in the image corresponding to a certain basis function/frequency.

Advantages of the Spectral Interpretation

The spectral interpretation allows to easily introduce in the coding process some relevant characteristics of the human visual system which are essential for efficient (lossy) coding.

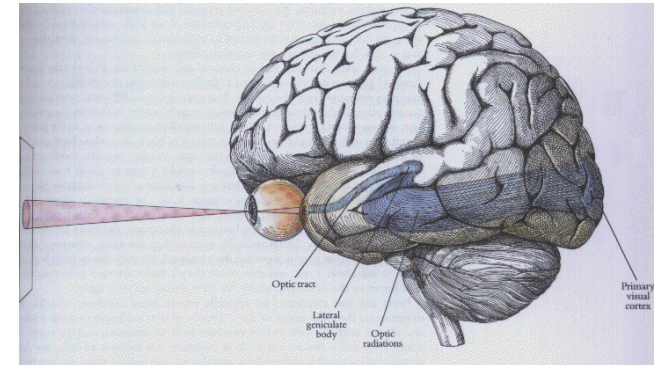

★ **The human visual system is less sensitive to the higher spatial frequencies**

->> **coarser coding (through quantization) of the corresponding transform coefficients**

★ **According to the Weber's Law, *the smallest change in the intensity of a stimulus capable of being perceived is proportional to the intensity of the original stimulus*, e.g. it is more difficult to see a change in a very white background**

->> **coarser coding (through quantization) of the coefficients depending on the amount of variation and context**

DCT versus KLT ...

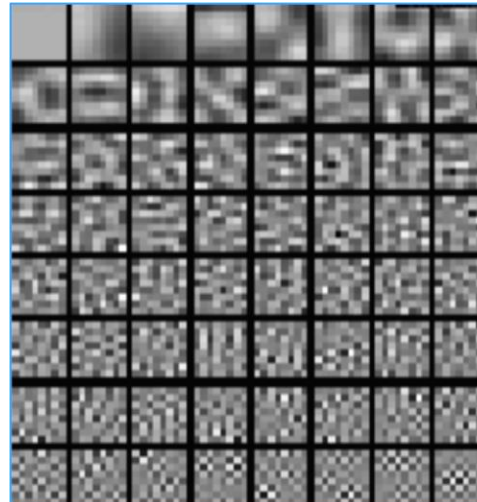
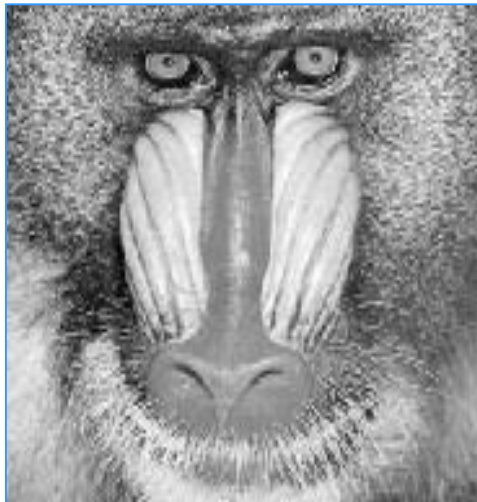

DCT: Same basis functions for any image block !

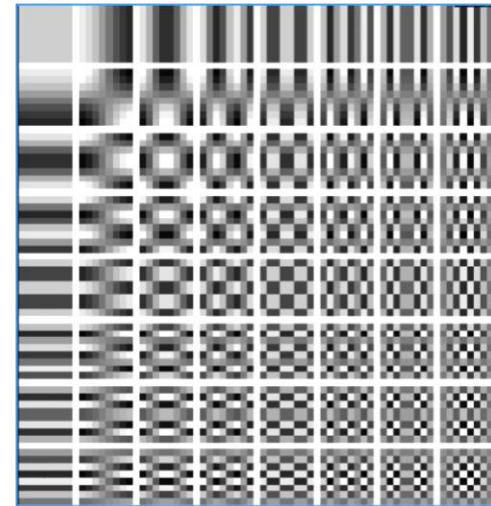

DCT for all blocks

KLT for a block

How Does the DCT Work ?

Spatial Domain, samples

Frequency Domain, DCT coefficients

X	X	X	X	X	X	X	X
X	X	X	X	X	X	X	X
X	X	X	X	X	X	X	X
X	X	X	X	X	X	X	X
X	X	X	X	X	X	X	X
X	X	X	X	X	X	X	X
X	X	X	X	X	X	X	X
X	X	X	X	X	X	X	X

DCT



x	y		a				
C	f	d					c
	H						k
Y			i				p
	q	d					
	n	m					
							z

Low frequency, high energy

High frequency, low energy

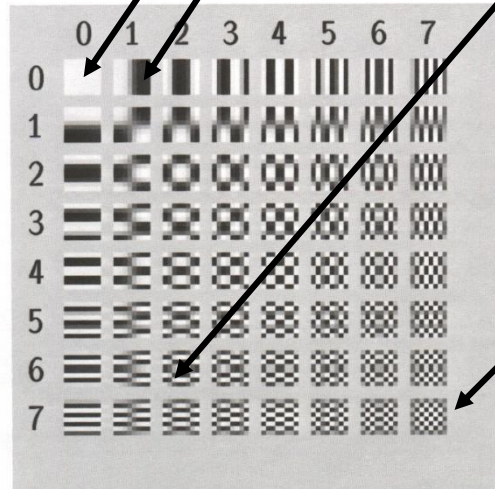

Since the DCT uses sinusoidal functions, it is impossible to perform computations with full precision. This leads to (slight) differences in the results for different implementations, so-called *decoding mismatch*.

- ★ To accommodate future (faster) implementation developments, the JPEG recommendation does not specify any specific DCT or IDCT implementation.
- ★ The JPEG recommendation specifies a fidelity/accuracy test regarding a reference implementation in order to limit the differences caused by the freedom in terms of DCT and IDCT implementation.

Note: The DCT is applied to the signal samples with P bits, with values between -2^{P-1} and $2^{P-1}-1$ in order the DC coefficient is distributed around zero.

DCT Based Image Coding

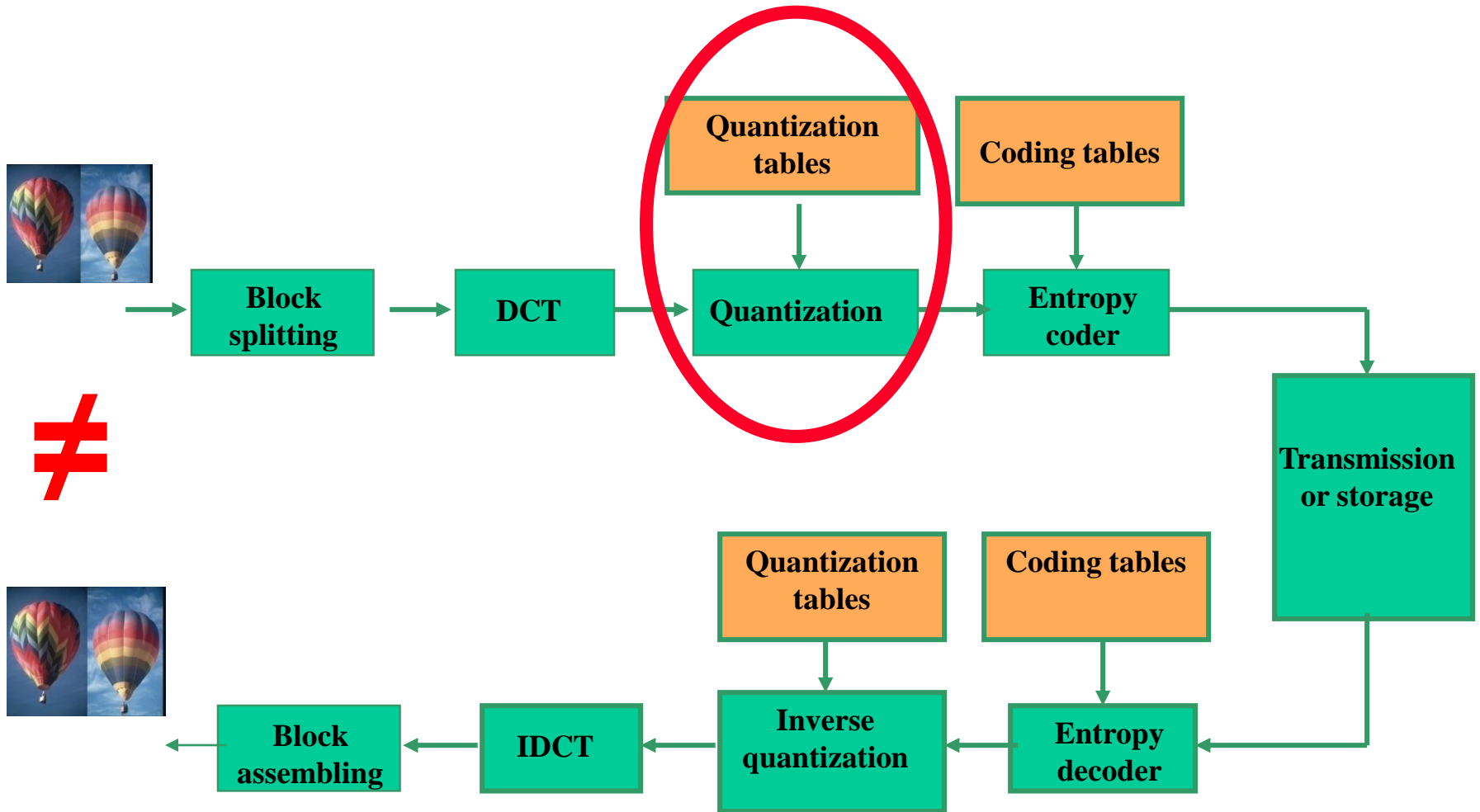

Quantization: Making the Codec Lossy ...

Quantization is the process by which irrelevancy or perceptual redundancy is reduced.

This process is the main responsible for the quality losses (but also the increased compression factors) in DCT based codecs (*but quality may be transparent even with quantization*).



Each quantization step may be selected taking into account the ‘minimum perceptual difference’ characteristics of the human visual system for the coefficient in question.

The quantization matrixes are not standardized but there is a suggested solution for ITU-R 601 resolution images (which still has to be coded).

How Does DCT Coding Work ?

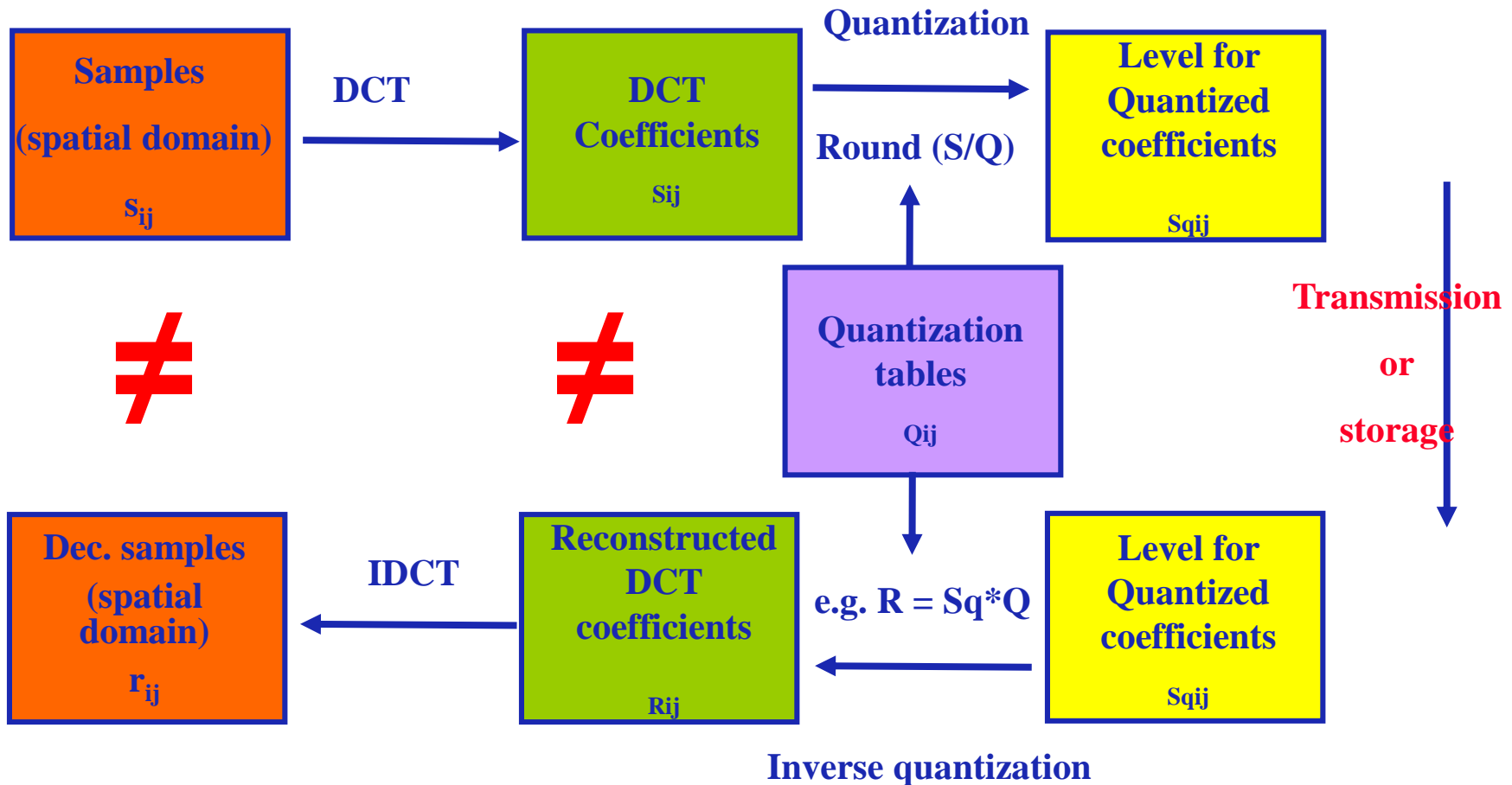
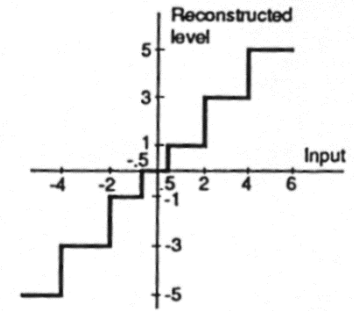

Quantization Matrices

For transparent quality, JPEG suggests to quantize the DCT coefficients using the values for the ‘minimum perceptual difference’ (for each coefficient) multiplied by 2; for more compression, a multiple of them may be used.

The quantization matrixes have to be always transmitted or at least signalled.

16	11	10	16	24	40	51	61
12	12	14	19	26	58	69	77
14	13	16	24	40	69	77	85
14	17	22	29	57	77	80	62
17	22	33	64	68	109	103	77
21	33	55	64	81	104	113	92
49	64	78	87	103	121	120	101
72	92	95	98	112	100	103	99

Luminance

17	18	24	47	99	99	99	99
18	21	26	66	99	99	99	99
24	26	56	99	99	99	99	99
47	66	99	99	99	99	99	99
99	99	99	99	99	99	99	99
99	99	99	99	99	99	99	99
99	99	99	99	99	99	99	99
99	99	99	99	99	99	99	99

Chrominances

Situation: Luminance and crominance with 2:1 horizontal subsampling; samples with 8 bits (*Lohscheller*)

898.0000	-149.5418	26.6464	-14.0897	0.7500	-5.7540	3.5750	0.0330
12.1982	-16.5235	-7.6122	5.2187	-0.2867	-1.9909	8.4265	1.2591
5.3355	-2.6557	2.3410	-9.9277	2.4614	4.4558	-3.1945	-3.1640
1.9463	-2.7271	1.5106	2.8421	-2.1336	-2.7203	-2.7510	5.4051
0.7500	-2.0745	0.8610	0.2085	2.5000	1.8446	2.0787	2.4750
7.9536	-2.6624	2.6308	0.4010	0.4772	3.3000	1.7394	0.3942
-4.1042	-0.1650	-0.6945	0.0601	0.0628	-0.7874	-0.8410	0.3496
-3.4688	2.3804	0.1559	0.8696	0.1142	-0.5240	-3.9974	-5.6187

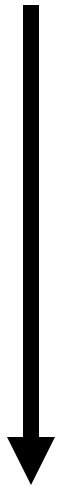

Quantizing ...

56	-14	3	-1	0	0	0	0
1	-1	-1	0	0	0	0	0
0	0	0	0	0	0	0	0
0	0	0	0	0	0	0	0
0	0	0	0	0	0	0	0
0	0	0	0	0	0	0	0
0	0	0	0	0	0	0	0
0	0	0	0	0	0	0	0

Finally, the
waited
miracle !



JPEG Coding: an Encoder Example

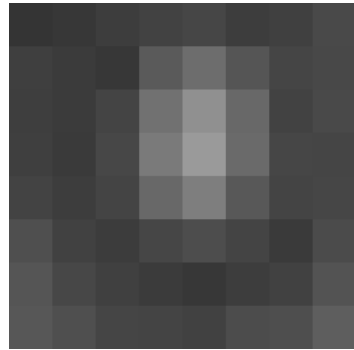

Original PCM

$$\begin{bmatrix} 52 & 55 & 61 & 66 & 70 & 61 & 64 & 73 \\ 63 & 59 & 55 & 90 & 109 & 85 & 69 & 72 \\ 62 & 59 & 68 & 113 & 144 & 104 & 66 & 73 \\ 63 & 58 & 71 & 122 & 154 & 106 & 70 & 69 \\ 67 & 61 & 68 & 104 & 126 & 88 & 68 & 70 \\ 79 & 65 & 60 & 70 & 77 & 68 & 58 & 75 \\ 85 & 71 & 64 & 59 & 55 & 61 & 65 & 83 \\ 87 & 79 & 69 & 68 & 65 & 76 & 78 & 94 \end{bmatrix}$$

Original PCM - 128

$$\begin{bmatrix} -76 & -73 & -67 & -62 & -58 & -67 & -64 & -55 \\ -65 & -69 & -73 & -38 & -19 & -43 & -59 & -56 \\ -66 & -69 & -60 & -15 & 16 & -24 & -62 & -55 \\ -65 & -70 & -57 & -6 & 26 & -22 & -58 & -59 \\ -61 & -67 & -60 & -24 & -2 & -40 & -60 & -58 \\ -49 & -63 & -68 & -58 & -51 & -60 & -70 & -53 \\ -43 & -57 & -64 & -69 & -73 & -67 & -63 & -45 \\ -41 & -49 & -59 & -60 & -63 & -52 & -50 & -34 \end{bmatrix}$$

$$\begin{bmatrix} -415.38 & -30.19 & -61.20 & 27.24 & 56.13 & -20.10 & -2.39 & 0.46 \\ 4.47 & -21.86 & -60.76 & 10.25 & 13.15 & -7.09 & -8.54 & 4.88 \\ -46.83 & 7.37 & 77.13 & -24.56 & -28.91 & 9.93 & 5.42 & -5.65 \\ -48.53 & 12.07 & 34.10 & -14.76 & -10.24 & 6.30 & 1.83 & 1.95 \\ 12.12 & -6.55 & -13.20 & -3.95 & -1.88 & 1.75 & -2.79 & 3.14 \\ -7.73 & 2.91 & 2.38 & -5.94 & -2.38 & 0.94 & 4.30 & 1.85 \\ -1.03 & 0.18 & 0.42 & -2.42 & -0.88 & -3.02 & 4.12 & -0.66 \\ -0.17 & 0.14 & -1.07 & -4.19 & -1.17 & -0.10 & 0.50 & 1.68 \end{bmatrix}$$

DCT Coefficients

Quantization Steps

$$\begin{bmatrix} 16 & 11 & 10 & 16 & 24 & 40 & 51 & 61 \\ 12 & 12 & 14 & 19 & 26 & 58 & 60 & 55 \\ 14 & 13 & 16 & 24 & 40 & 57 & 69 & 56 \\ 14 & 17 & 22 & 29 & 51 & 87 & 80 & 62 \\ 18 & 22 & 37 & 56 & 68 & 109 & 103 & 77 \\ 24 & 35 & 55 & 64 & 81 & 104 & 113 & 92 \\ 49 & 64 & 78 & 87 & 103 & 121 & 120 & 101 \\ 72 & 92 & 95 & 98 & 112 & 100 & 103 & 99 \end{bmatrix}$$

$$\begin{bmatrix} -26 & -3 & -6 & 2 & 2 & -1 & 0 & 0 \\ 0 & -2 & -4 & 1 & 1 & 0 & 0 & 0 \\ -3 & 1 & 5 & -1 & -1 & 0 & 0 & 0 \\ -3 & 1 & 2 & -1 & 0 & 0 & 0 & 0 \\ 1 & 0 & 0 & 0 & 0 & 0 & 0 & 0 \\ 0 & 0 & 0 & 0 & 0 & 0 & 0 & 0 \\ 0 & 0 & 0 & 0 & 0 & 0 & 0 & 0 \\ 0 & 0 & 0 & 0 & 0 & 0 & 0 & 0 \end{bmatrix}$$

Quantized DCT Coeffs

JPEG Coding: a Decoder Example

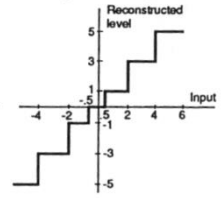

Quantized DCT Coeffs

$$\begin{bmatrix} -26 & -3 & -6 & 2 & 2 & -1 & 0 & 0 \\ 0 & -2 & -4 & 1 & 1 & 0 & 0 & 0 \\ -3 & 1 & 5 & -1 & -1 & 0 & 0 & 0 \\ -3 & 1 & 2 & -1 & 0 & 0 & 0 & 0 \\ 1 & 0 & 0 & 0 & 0 & 0 & 0 & 0 \\ 0 & 0 & 0 & 0 & 0 & 0 & 0 & 0 \\ 0 & 0 & 0 & 0 & 0 & 0 & 0 & 0 \\ 0 & 0 & 0 & 0 & 0 & 0 & 0 & 0 \end{bmatrix}$$

Dequantized DCT Coeffs

$$\begin{bmatrix} -416 & -33 & -60 & 32 & 48 & -40 & 0 & 0 \\ 0 & -24 & -56 & 19 & 26 & 0 & 0 & 0 \\ -42 & 13 & 80 & -24 & -40 & 0 & 0 & 0 \\ -42 & 17 & 44 & -29 & 0 & 0 & 0 & 0 \\ 18 & 0 & 0 & 0 & 0 & 0 & 0 & 0 \\ 0 & 0 & 0 & 0 & 0 & 0 & 0 & 0 \\ 0 & 0 & 0 & 0 & 0 & 0 & 0 & 0 \\ 0 & 0 & 0 & 0 & 0 & 0 & 0 & 0 \end{bmatrix}$$

Inverse DCT Output

$$\begin{bmatrix} -66 & -63 & -71 & -68 & -56 & -65 & -68 & -46 \\ -71 & -73 & -72 & -46 & -20 & -41 & -66 & -57 \\ -70 & -78 & -68 & -17 & 20 & -14 & -61 & -63 \\ -63 & -73 & -62 & -8 & 27 & -14 & -60 & -58 \\ -58 & -65 & -61 & -27 & -6 & -40 & -68 & -50 \\ -57 & -57 & -64 & -58 & -48 & -66 & -72 & -47 \\ -53 & -46 & -61 & -74 & -65 & -63 & -61 & -45 \\ -47 & -34 & -53 & -74 & -60 & -47 & -47 & -41 \end{bmatrix}$$

$$\begin{bmatrix} 62 & 65 & 57 & 60 & 72 & 63 & 60 & 82 \\ 57 & 55 & 56 & 82 & 108 & 87 & 62 & 71 \\ 58 & 50 & 60 & 111 & 148 & 114 & 67 & 64 \\ 65 & 55 & 66 & 120 & 155 & 114 & 68 & 70 \\ 70 & 63 & 67 & 101 & 122 & 88 & 60 & 78 \\ 71 & 71 & 64 & 70 & 80 & 62 & 56 & 81 \\ 75 & 82 & 67 & 54 & 63 & 65 & 66 & 83 \\ 81 & 95 & 75 & 54 & 68 & 81 & 81 & 87 \end{bmatrix}$$

$$\begin{bmatrix} -10 & -10 & 4 & 6 & 2 & 2 & 4 & -9 \\ 6 & 4 & -1 & 8 & 1 & -2 & 7 & 1 \\ 4 & 9 & 8 & 2 & -4 & -10 & -1 & 8 \\ -2 & 3 & 5 & 2 & -1 & -8 & 2 & -1 \\ -3 & -2 & 1 & 3 & 4 & 0 & 8 & -8 \\ 8 & -6 & -4 & 0 & -3 & 6 & 2 & -6 \\ 10 & -11 & -3 & 5 & -8 & -4 & -1 & 0 \\ 6 & -15 & -6 & 14 & -3 & -5 & -3 & 7 \end{bmatrix}$$

Original block

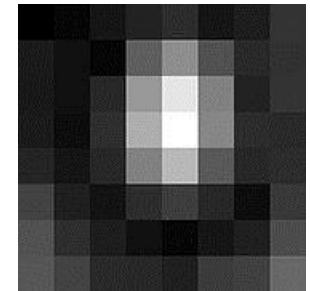

Decoded block

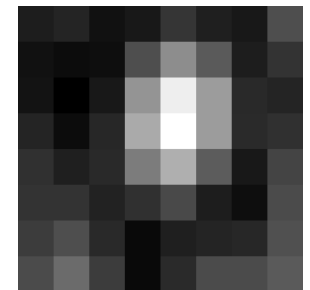

Inverse DCT Output + 128

Coding error

Photo with the compression rate decreasing, and hence quality increasing, from left to right.

DCT coefficients selection and quantization are the secrets !



DCT Based Image Coding

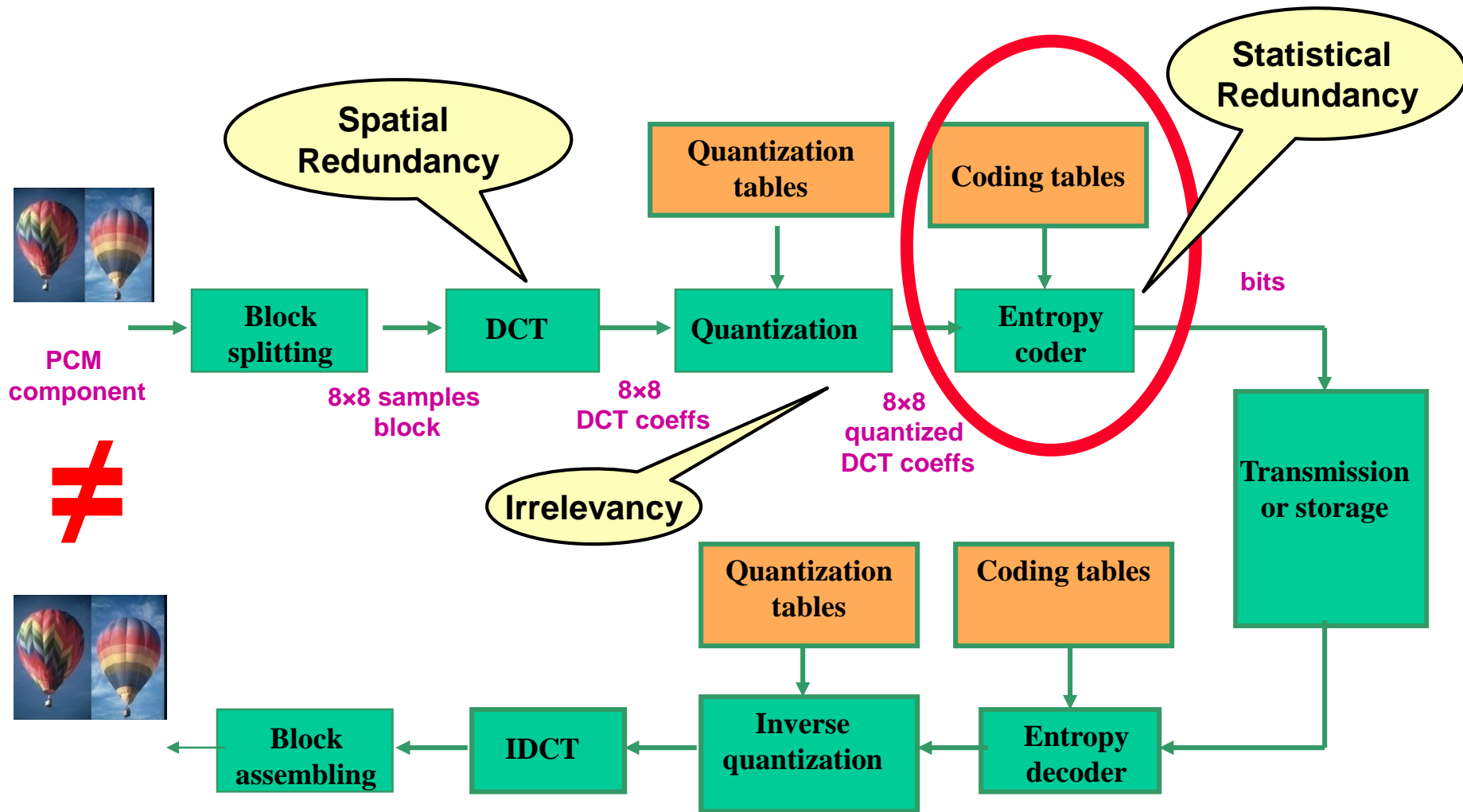

Zig-Zag Serializing the Quantized Coefficients

124	25	0	0	0	0	23	0
147	0	13	0	0	78	190	248
126	147	0	0	0	0	0	0
0	10	0	0	15	0	183	119
40	0	0	0	83	0	0	0
94	0	0	173	0	0	0	0
0	0	0	56	0	0	0	0
203	0	0	0	0	0	0	0

Each DCT block is represented as a sequence of (run, level) pairs, e.g. (0,124), (0, 25), (0,147), (0, 126), (3,13), (0, 147), (1,40) ...

- ★ For the decoder to reconstruct the matrix with the quantized DCT coefficients, the position and amplitude of the non-null coefficients has to be coded, one after another.
- ★ The position of each quantized DCT coefficient may be sent in a relative or absolute way.
- ★ The JPEG solution is to send the position of each non-null quantized DCT coefficient through a *run* indicating the number of null DCT coefficients existing between the current and the previous non-null coefficient.

Generating the Symbols

The first step is to decide which symbols to entropy code, this means which (*run-level*) pairs represent each 8×8 block.

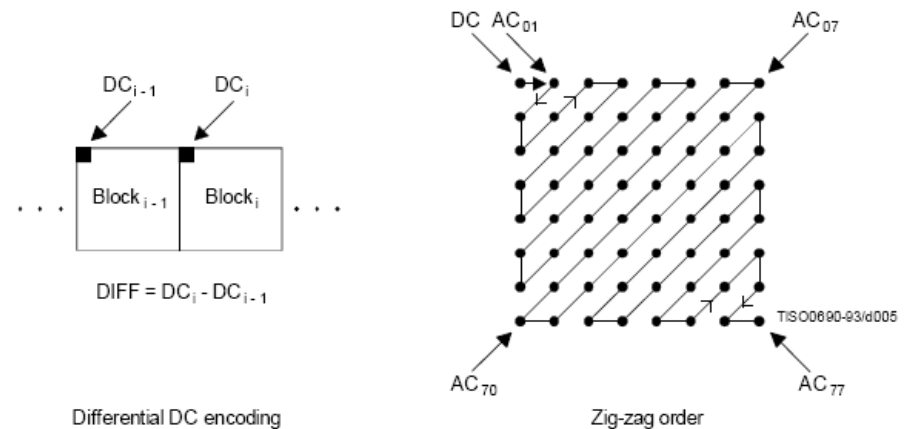

- ★ **DC coefficient** - The DC coefficient is treated differently (using differential prediction) because of the high correlation between the DC coefficients of adjacent 8×8 blocks as these coefficients are proportional to the average of the block.
- ★ **AC coefficients** - The AC quantized coefficients are zig-zag ordered to facilitate entropy coding, creating shorter runs; this also implies coding the lower frequency coefficients before the higher frequency coefficients in a perceptually prioritized order.

The precise definition of the symbols to encode depends on the DCT operation mode and the type of entropy coding.

WHY DON'T YOU
CLEAN YOUR
ROOM? IT'S SO
UNORGANIZED!



MOM, I CAN TOTALLY
DO THAT ... BUT IT GOES
AGAINST THE CONCEPT
OF ENTROPY AND THE
NATURAL ORDER OF
THINGS!



The **principle of maximum entropy** states that, subject to precisely stated prior data, the probability distribution which best represents the current state of knowledge is the one with largest entropy.

In information theory, entropy is a measure of uncertainty associated with a variable. Higher the uncertainty, higher the entropy!

Entropy coding tries to match the *number of bits* used to code a *symbol/stream of symbols* with its entropy.

Information Theory: Source Entropy

Information Theory states that there is a lower limit for the average number of bits per symbol when coding m symbols from a source of information, each one with probability p_i . This limit is given by the source entropy:

$$H = \sum p_i \log_2 (1/p_i) \quad \text{bit/symbol}$$

- **The source entropy:**
 - **Measures the average amount of information carried by each symbol output by the source**
 - **Is a convex function of the probabilities p_i**
 - **Takes its maximum value when all symbols have the same probability (all p_i are the same)**
 - **Takes a maximum value of $\log_2 m$ bit/symbol**

Information Theory does not indicate how to obtain a code with this coding efficiency but there are methods which allow to obtain codes with an efficiency as close as desired to the entropy efficiency.

Entropy coding allows encoding (into bits) the symbols issued by a source, taking into account their statistical distribution.

Entropy coding:

- (+) Increases the final compression efficiency**
- (+) Does not degrade the coded signal, this means it is lossless**
- (-) Produces a highly time varying bitstream**
- (-) Increases the sensibility to transmission errors**
- (*) Provides compression in statistical terms, not necessarily symbol by symbol**

Huffman (VLC) Coding

Símbolo	Probabilidade redução 0	Palav. Código redução 0	Probabilidade redução 1	Palav. Código redução 1
A	0.7	0	0.7	0
B	0.2	1 0	0.3	1
C	0.1	1 1		

Huffman coding allows obtaining a code with an average number of bits per symbol as close as desired to the source entropy.

But this requires knowledge on the source statistics, i.e., symbol probabilities.

Entropy = 1.157 bit/symbol
 $(H = \sum p_i \log_2 (1/p_i) \text{ bit/symbol})$

Average code length = 1.3 bit/symbol

Efficiency = 1.157/1.3 = 89%



Huffman Coding: 2^a Order Extension



2nd extension

Source	Reduction 1	Reduction 2
AA	0.49	1
AB	0.14	000
BA	0.14	001
AC	0.07	0100
CA	0.07	0101
BB	0.04	0111
BC	0.02	01101
CB	0.02	011000
CC	0.01	011001

2nd extension Red. 3 Red. 4 Red. 5 Red. 6 Red. 7

AA	0.49	1	0.49	1	0.49	1	0.49	1	0.51	0
AB	0.14	000	0.14	000	0.23	01	0.28	00	0.49	1
BA	0.14	001	0.14	001	0.14	000	0.23	01		
AC	0.09	011	0.14	010	0.14	001				
CA	0.07	0100	0.09	011						
BB	0.07	0101								
BC										
CB										
CC										

Entropy = 1.157 bit/symbol

Average code length for 2nd order extension = 2.33 bit/extension symbol

Average code length = 2.33/2 = 1.165 bit/symbol

Efficiency = 1.157/1.165 = 99,3 %

Back to JPEG ... The Symbols to Code ...

Each DCT block is represented as a sequence of (run, level) pairs, notably

56	-14	3	-1	0	0	0	0
1	-1	-1	0	0	0	0	0
0	0	0	0	0	0	0	0
0	0	0	0	0	0	0	0
0	0	0	0	0	0	0	0
0	0	0	0	0	0	0	0
0	0	0	0	0	0	0	0
0	0	0	0	0	0	0	0

DC: (0, 56)

AC1: (0, -14)

AC2: (0, 1)

AC4: (1, -1)

AC5: (0, 3)

AC6: (0, -1)

AC7: (0, -1)

EOB (End of Block)

Small
runs are
highly
probable !

Entropy coding uses the statistics of the symbols to code to reach (lossless) additional (entropy) compression.

For JPEG Baseline, entropy coding includes two phases:

- ★ **(RUN, LEVEL) PAIRS TO SYMBOLS** - Conversion of the sequence of *(run, level)* pairs associated to the DCT coefficients, zig-zag ordered into an intermediary sequence of symbols (*symbols 1 and 2* in the following)
- ★ **SYMBOLS TO BITS** - Conversion of the sequence of intermediary symbols (*symbols 1 and 2*) into a sequence of bits without externally identifiable boundaries

Entropy Coding: Intermediary Symbols

Each non-null AC coefficient is represented using the number of null DCT coefficients preceding it in the zig-zag scanning (*position*) using a *run* in 0..62 and its *quantization level (amplitude)*.

Each (*run, level*) pair associated to a non-null AC coefficient is represented by a pair of symbols:



Symbol 1 - Huffman (bidimensional)

Symbol 2 - VLI

- ★ *Run* - number of null DCT coefficients preceding the coefficient being coded in the zig-zag scanning
- ★ *Size* – number of bits used to code the *Level* (this means Symbol 2)
- ★ *Level* – quantization level of the DC coefficient to be coded

Each DC coefficient is represented in the same way, with the *run* equal to zero.

Coding Tables for Symbols 1 and 2

	0	1	2	Size	9	10
Runlength	0	EOB	Run-size values			
	.	X				
	.	X				
	.	X				
	15	ZRL				

Size	Amplitude
1	-1, 1
2	-3, -2, 2, 3
3	-7 ... -4, 4 ... 7
4	-15 ... -8, 8 ... 15
5	-31 ... -16, 16 ... 31
6	-63 ... -32, 32 ... 63
7	-127 ... -64, 64 ... 127
8	-255 ... -128, 128 ... 255
9	-511 ... -256, 256 ... 511
10	-1023 ... -512, 512 ... 1023

Symbol 1: (*run, size*)

Bidimensional

Huffman coding

With some
pragmatism for runs
longer than 15 !

Symbol 2: (*level*)

VLI coding

VLI Coding Example: +12 and -12



Symbol 1 - Huffman (bidimensional)

Symbol 2 - VLI

0000 -15

0001 -14

0010 -13

0011 -12

0100 -11

0101 -10

0110 -9

0001 -8

1000 8

1001 9

1010 10

1011 11

1100 12

1101 13

1110 14

1111 15



1100

+12 in binary

after 'inverting' all bits

The code for negative values is simply the 'inversion' of the code for positive values.



1100

+12 in binary

Entropy Coding: Summary

(run, level) =>



Symbol 1 - Huffman (bidimensional)

Symbol 2 - VLI

	0	1	2	Size	9	10
Runlength	0	EOB	Run-size values			
	.	X				
	.	X				
	.	X				
	15	ZRL				

Size	Level
1	-1, 1
2	-3, -2, 2, 3
3	-7 ... -4, 4 ... 7
4	-15 ... -8, 8 ... 15
5	-31 ... -16, 16 ... 31
6	-63 ... -32, 32 ... 63
7	-127 ... -64, 64 ... 127
8	-255 ... -128, 128 ... 255
9	-511 ... -256, 256 ... 511
10	-1023 ... -512, 512 ... 1023

JPEG Coding Model

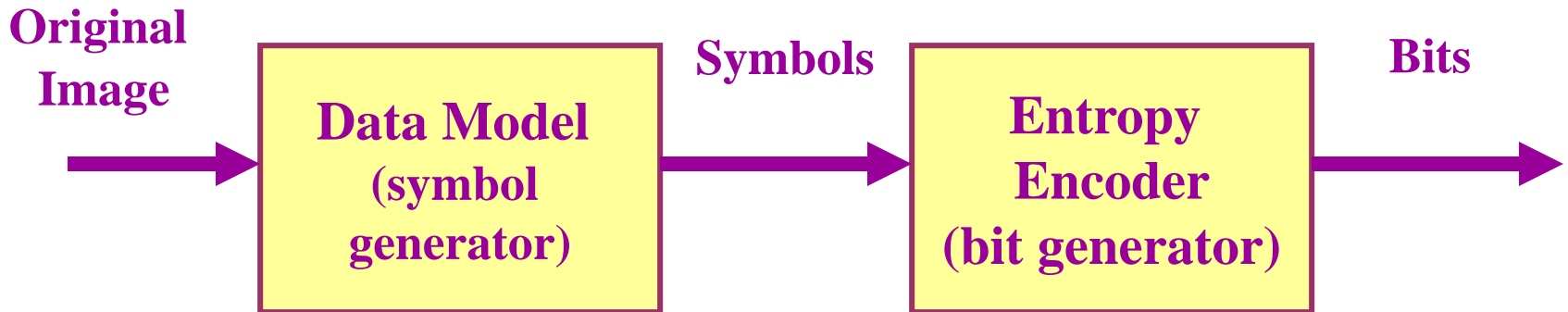

JPEG Model: An image is represented as a sequence of (almost) independent 8×8 samples blocks with each block represented by means of a zig-zag sequence of quantized DCT coefficients using (*run, level*) pairs, terminated by a *End of Block*.

Compression versus Quality



JPEG offers the following levels of compression/quality for sequential DCT based coding, considering colour images with medium complexity:

- ★ **0.25 - 0.5 bit/pixel – medium to good quality; enough for some applications**
- ★ **0.5 - 0.75 bit/pixel – good to very good quality; enough for many applications**
- ★ **0.75 - 1.5 bit/pixel – excellent quality; enough for most applications**
- ★ **1.5 - 2.0 bit/pixel – transparent quality; enough for the most demanding applications**

These compression/quality levels are only indicative since the compression always depends on the specific image content, notably if there is more or less spatial redundancy and irrelevancy.

The quality level may be controlled through the quantization steps.

JPEG Test Images



Barb 1



Barb 2



Board



Boats



Hill



Hotel



Zelda



Toys

Performance Assessment Experiment

Conditions:

- ★ Baseline coding process (DCT based), using the quantization tables suggested in the JPEG standard and Huffman/VLI coding with optimized tables and ITU-T 601 spatial resolution.
- ★ A JPEG with optimized tables is simply a JPEG stream including custom Huffman tables created after the statistical analysis of the image's unique content.

Conclusions:

- ★ Most of the signal energy is concentrated on the luminance component.
- ★ Most of the bits are used for AC DCT coefficients.
- ★ *Barb1* and *Barb2* test images, which are richer in high frequencies, lead to lower compression factors, although still within the JPEG compression/quality targets.

Performance Results

Imagem	Coef. DC Lum (byte)	Coef DC crom (byte)	Coef AC Lum (byte)	Coef AC Crom (byte)	Global (byte)	Factor Comp.	Ritmo (bit/pel)	SNR Y (dB)	SNR U (dB)	SNR V (dB)
Zelda	4208	2722	19394	3293	29617	28.00	0.571	38.09	42.01	40.98
Barb1	4520	2926	40995	4878	53319	15.56	1.028	33.39	38.38	39.01
Boats	3833	2255	29302	3755	39145	21.19	0.755	35.95	41.13	40.13
Black	3497	2581	21260	6015	33353	24.87	0.643	37.75	40.09	38.23
Barb2	4223	2933	41613	7246	56014	14.81	1.080	32.37	37.05	36.09
Hill	4007	2206	34890	3727	44830	18.50	0.865	34.31	39.83	38.09
Hotel	4239	2708	35520	6658	49125	16.88	0.945	34.55	37.95	36.99

Summary: How Does JPEG Compress ?

★ Spatial Redundancy

- Image samples statistically dependent are converted into uncorrelated DCT coefficients with the signal energy concentrated in the smallest possible number of coefficients

★ Irrelevancy

- DCT coefficients are quantized using psychovisual criteria

★ Statistical Redundancy

- The statistics of the symbols is exploited using *run-length* coding and Huffman entropy coding (or arithmetic coding)

JPEG Extensions

Making JPEG more powerful and flexible



The various JPEG operational modes address the need to provide solutions for a large range of applications with different requirements.

- ★ **SEQUENTIAL MODE** – Each image component is coded in a single scan (from top to bottom and left to right).
- ★ **PROGRESSIVE MODE** - The image is coded with several scans which offer a successively better quality (but same spatial resolution).
- ★ **HIERARCHICAL MODE** - The image is coded in several resolutions exploiting their mutual dependencies, with lower resolution images available without decoding higher resolution images.
- ★ **LOSSLESS MODE** – This mode guarantees the exact reconstruction of each sample in the original image (mathematical equality).

For each operation mode, one or more codecs are specified; these codecs are different in the sample precision (bit/sample) or the entropy coding method.

Progressive versus Sequential Modes

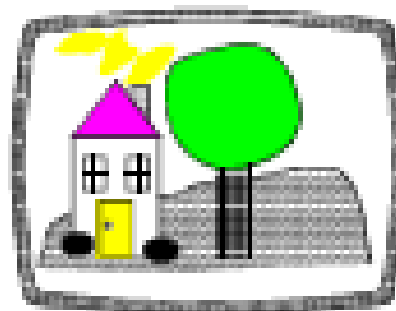
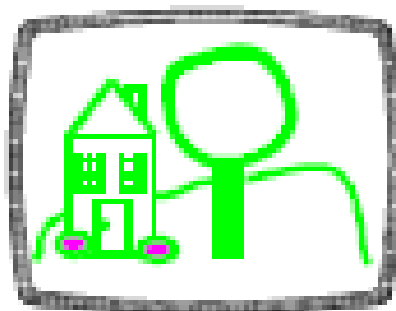
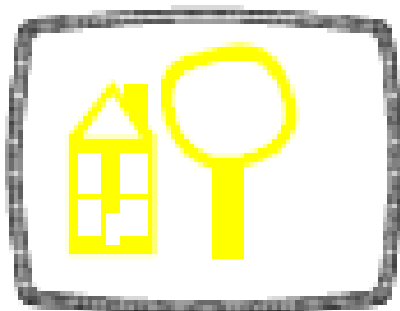

Progressive

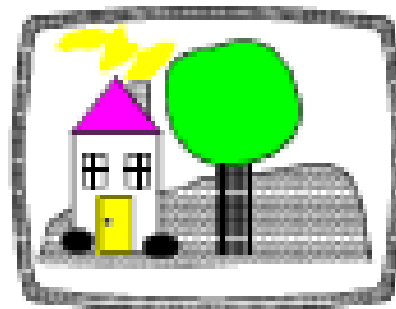
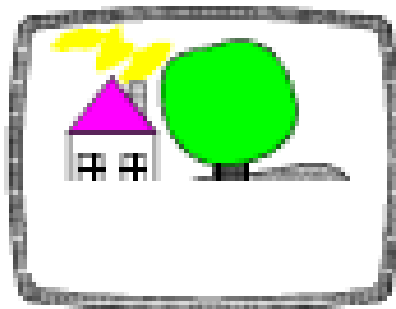

Sequential

TG000733-63/2006

Sequential Mode or No Scalability ...

NON scalable stream

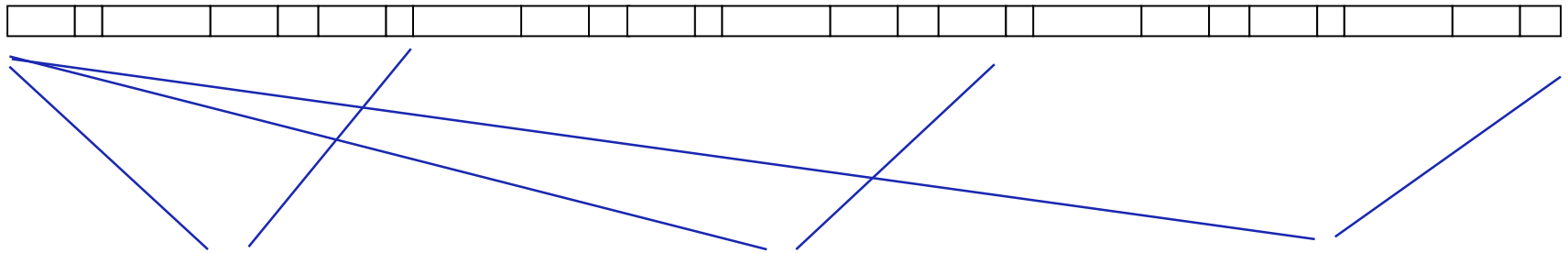

Decoding 1

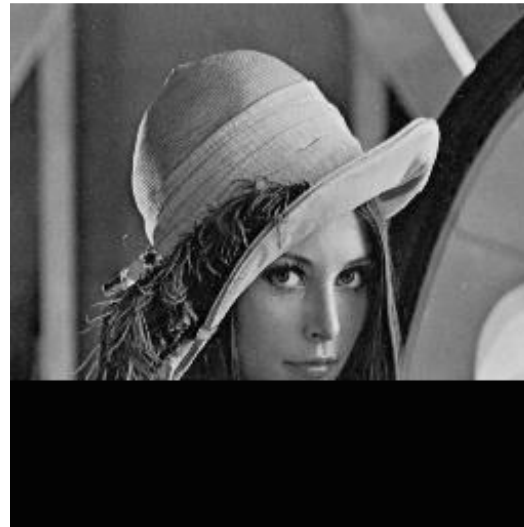

Decoding 2



Decoding 3

Progressively More Quality: Quality or SNR Scalability

Scalable stream

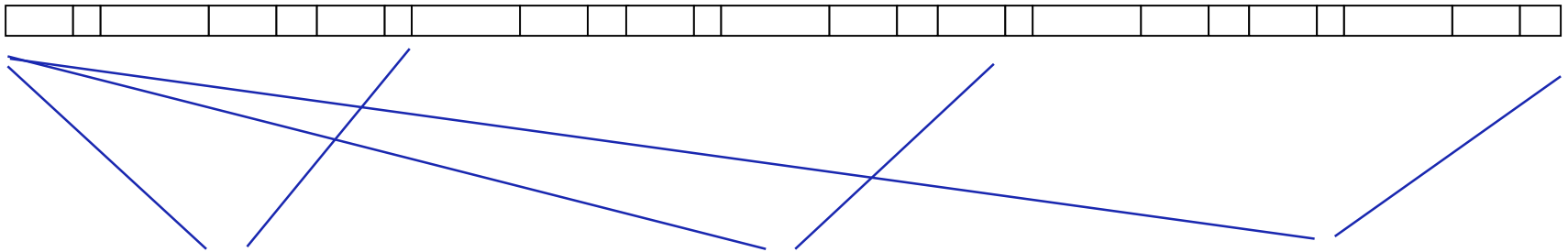

Decoding 1

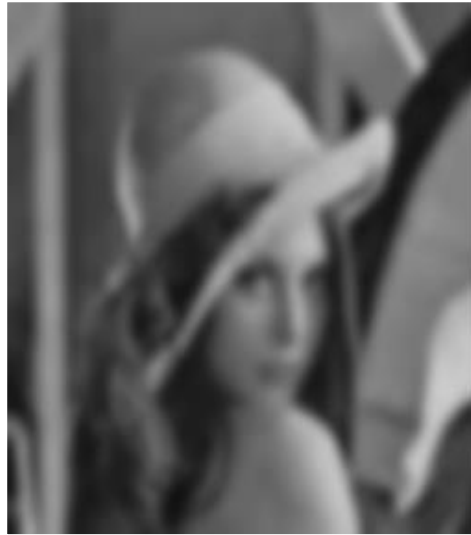

Decoding 2



Decoding 3

JPEG Progressive Mode



The image is coded with successive scans. The first scan gives very quickly an idea about the image content; after, the quality of the decoded image is progressively improved with the successive scans (quality layers).

The implementation of the progressive mode requires a memory with the size of the image to store the quantized DCT coefficients (11 bits for the baseline process) which will be partially coded with each scan.

There are two methods of implementing the progressive mode:

- ★ **SPECTRAL SELECTION – Only a specified 'zone' of the DCT coefficients is coded in each scan (going from lower to higher frequencies)**
- ★ **GROWING PRECISION – DCT coefficients are coded with successively higher precision, bitplane after bitplane**

The spectral selection and successive approximations methods may be applied separately or combined.

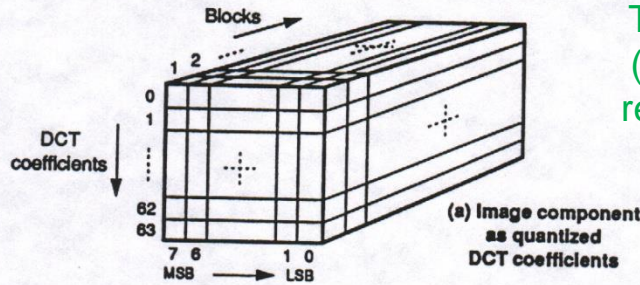

This cuboid includes all (quantized) information representing the image !

Spectral selection: Each layer brings an increasing number of DCT coefficients, and thus frequencies

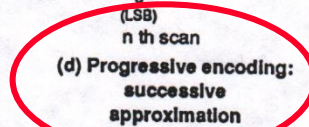
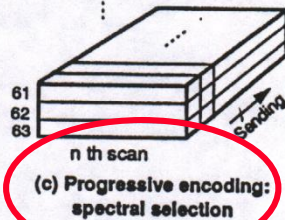
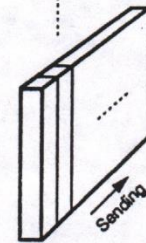
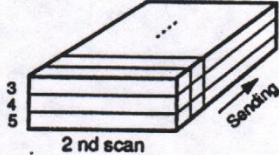
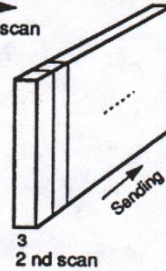
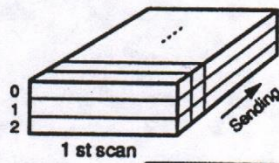
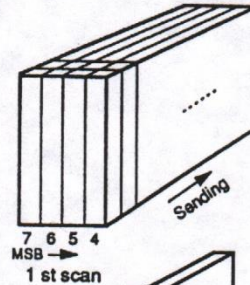
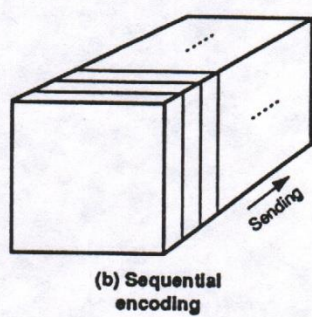

Successive approximation: Each layer brings an increasing (mathematical) precision for all coefficients

Progressive Modes: Spectral Selection and Growing Precision

Hierarchical Mode or Spatial Scalability ...

Scalable stream

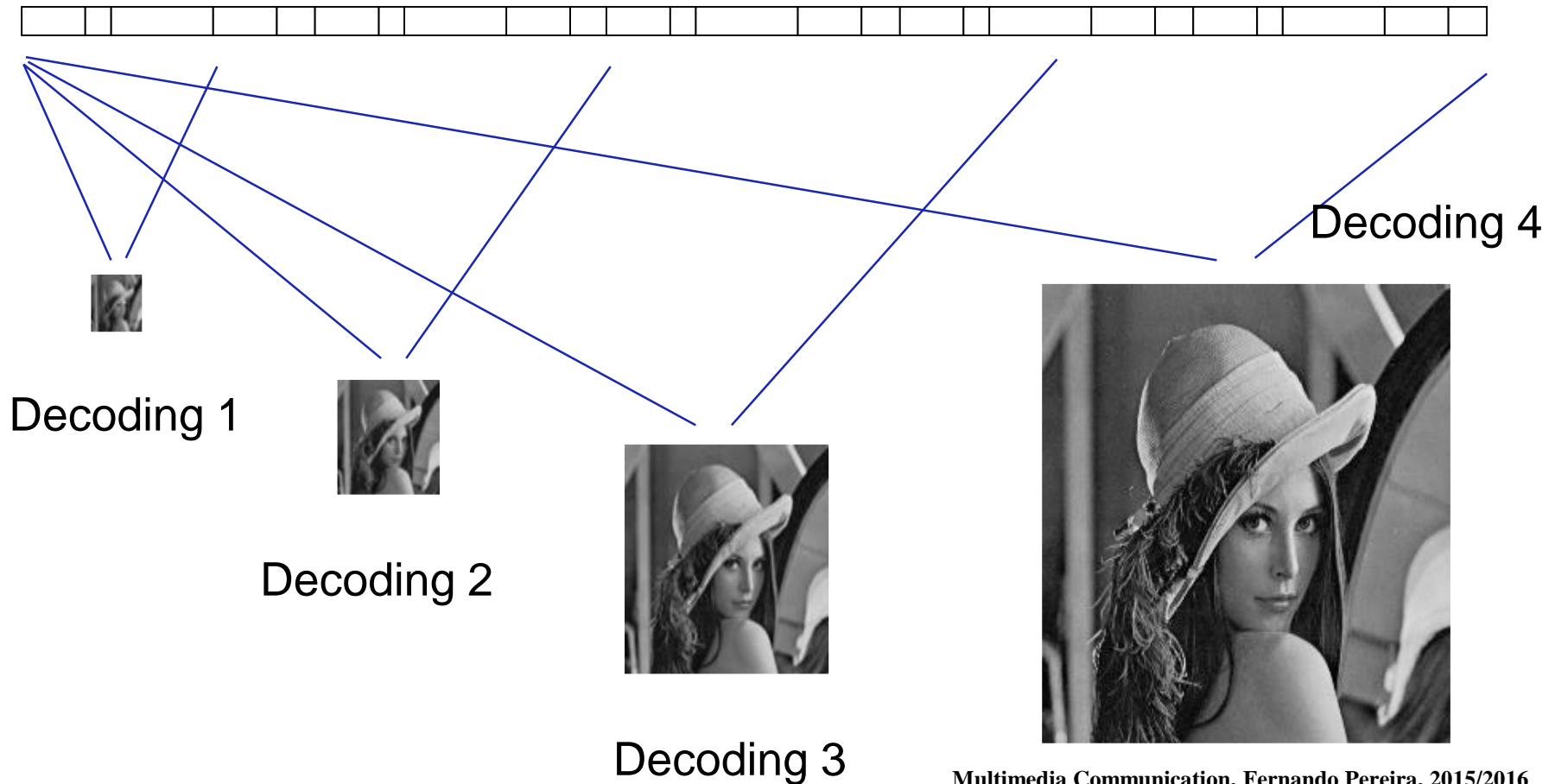

Hierarchical Mode

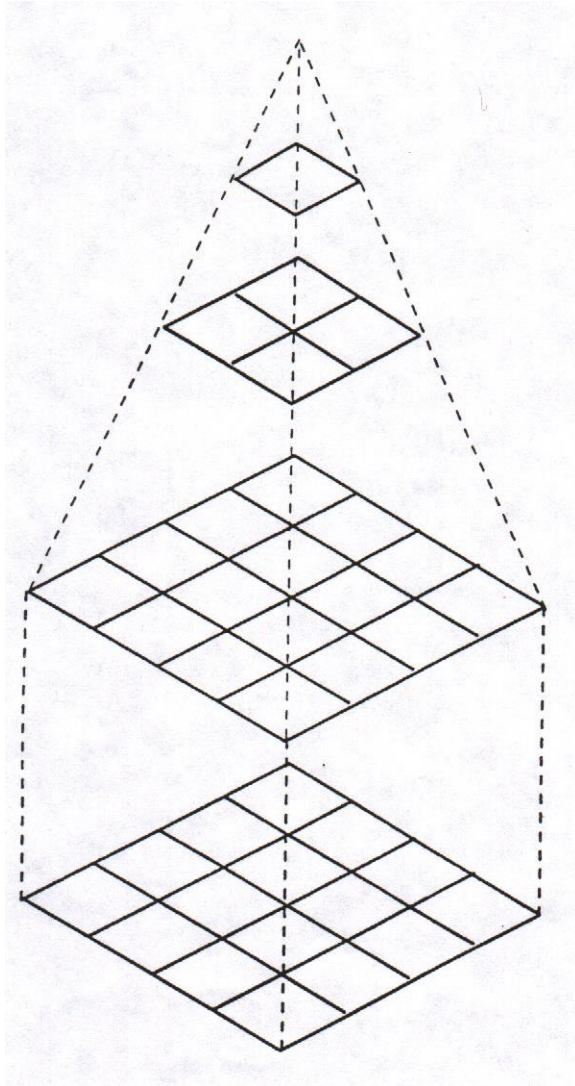

- ★ **The hierarchical mode implements a pyramidal coding of the image with several spatial resolutions. Each (higher) resolution multiplies by 2 the number of vertical and horizontal samples.**
- ★ **JPEG hierarchical coding may integrate in the various layers, lossless coding as well as DCT based coding.**

Image Pyramid

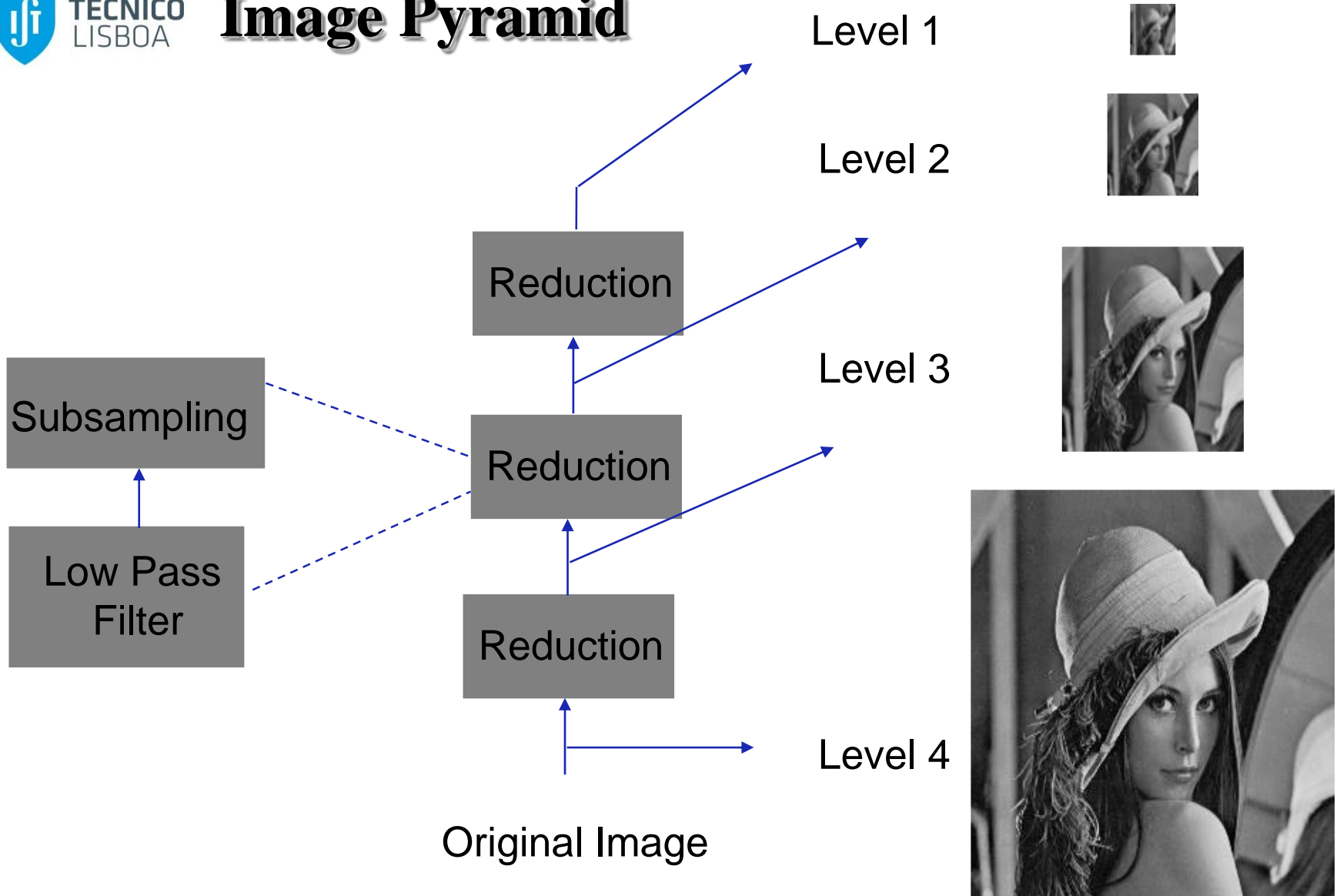

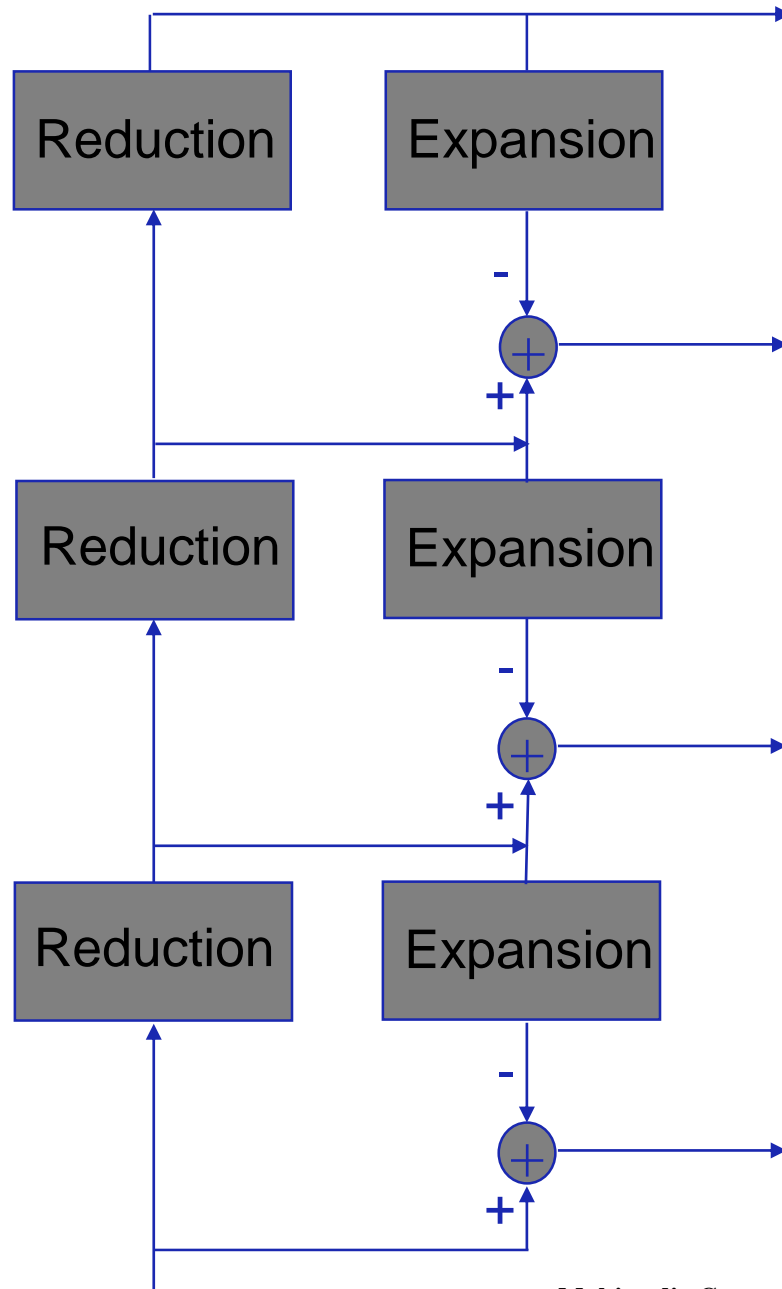

Original Image

Hierarchical Encoder

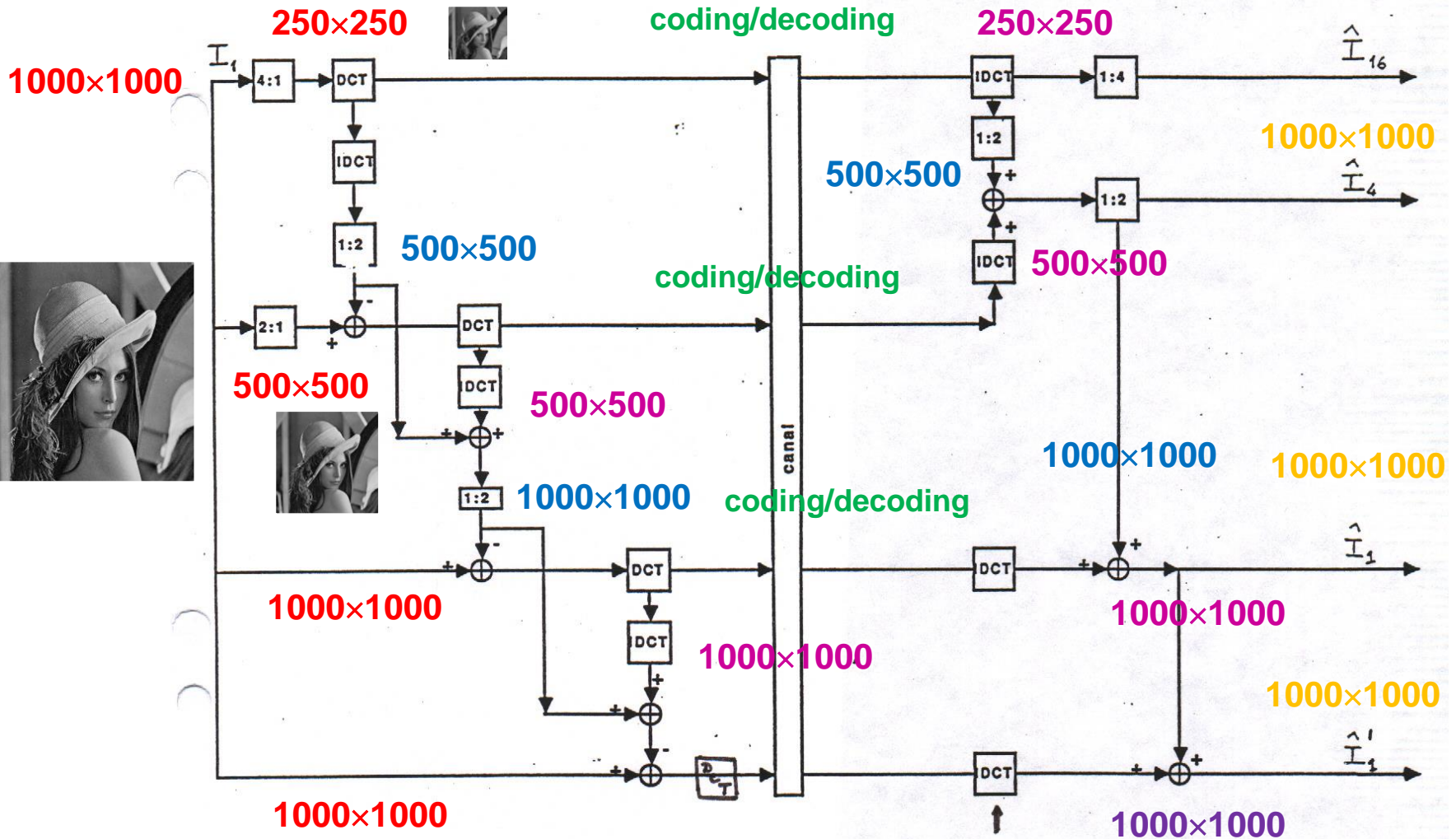

JPEG Lossless Mode

The JPEG lossless mode is based on a spatial prediction scheme. The prediction combines the values of, at most, 3 adjacent pixels. Finally, the *prediction mode* and the *prediction error* are coded.

- ★ **This JPEG coding mode is rather popular for medical imaging.**
- ★ **The definition of a DCT based lossless mode would require a much more precise/rigid definition of the codecs, e.g. DCT implementation.**
- ★ **Two JPEG lossless codecs are specified, one using Huffman coding and another using arithmetic coding.**
- ★ **The codecs may use any precision between 2 and 16 bit/sample.**
- ★ **The JPEG lossless mode offers ≈ 2:1 compression for colour images of medium complexity.**
- ★ **There is also a JPEG-LS standard developed later, allowing to achieve better compression factors (≈ 3:1).**

Lossless Coding

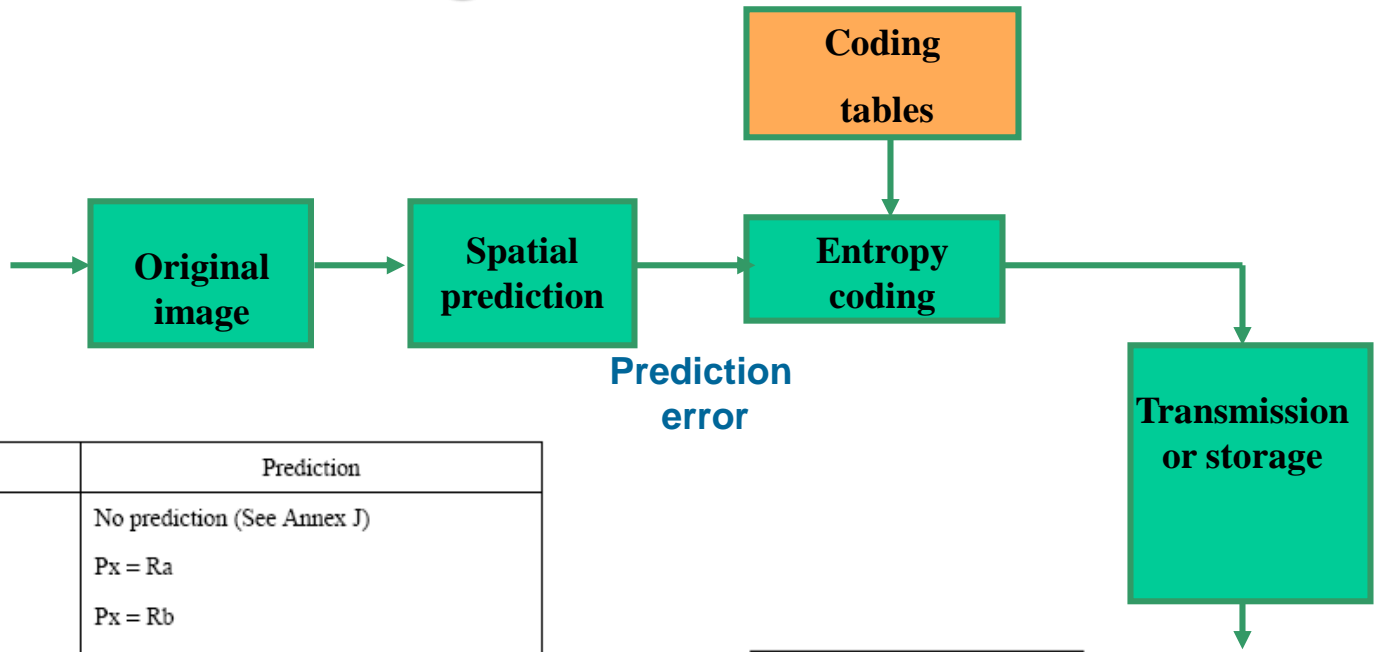

Selection-value	Prediction
0	No prediction (See Annex J)
1	$P_x = R_a$
2	$P_x = R_b$
3	$P_x = R_c$
4	$P_x = R_a + R_b - R_c$
5	$P_x = R_a + ((R_b - R_c)/2)^{a)}$
6	$P_x = R_b + ((R_a - R_c)/2)^{a)}$
7	$P_x = (R_a + R_b)/2$

a) Shift right arithmetic operation

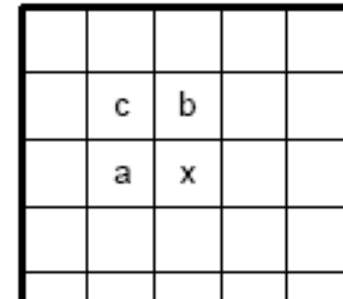

P_x is the prediction and R_a , R_b , and R_c are the reconstructed samples immediately to the left, above, and diagonally to the left of the current sample.

x is the sample to code

What Makes a Compression Technology Successful ?

- ★ Adoption in a standard
- ★ Compression performance
- ★ Encoder and decoder complexity
- ★ Error resilience
- ★ Random access
- ★ Scalability
- ★ Added value regarding alternative solutions/standards
- ★ Patents and licensing issues
- ★ Adoption companies
- ★ Marketing issues
- ★ ...



Image Coding: Multiple Solutions

JPEG Standards

- ★ JPEG - DCT-based transform coding
- ★ JPEG-LS - Lossless coding
- ★ JPEG 2000 - Wavelet-based coding
- ★ JPEG XR - Lapped biorthogonal-based transform coding

JPEG

JPEG
2000

Other Solutions

- ★ Fractal-based coding
- ★ Vector quantization coding
- ★ GIF, TIFF, PNG
- ★ H.264/AVC Intra, HEVC Intra

JPEG is nowadays almost a *raw format* as many cameras don't even make available the PCM format.

- ★ **JPEG: Still Image Data Compression Standard**, William Pennebaker, Joan Mitchell, Kluwer Academic Publishers, 1993
- ★ **Image and Video Compression Standards: Algorithms and Architectures**, Vasudev Bhaskaran and Konstantinos Konstantinides, Kluwer Academic Publishers, 1995
- ★ **Digital Image Compression Techniques**, Majid Rabbani, Paul W. Jones, SPIE Press, Tutorial texts on Optical Engineering, 1991